



---

# **Real Time Simulation of Vehicle Power and Propulsion Systems Using Opal-RT Real Time Tools**

M. Ehsani, Ph.D, PE, F. IEEE  
Robert M. Kennedy Endowed Professor & Director,  
Advanced Vehicle Systems Research Program  
Texas A&M University  
College Station, TX 77843-3128  
Tel. : (979) 845-7582  
Fax: (979) 845-6259  
E-mail: [ehsani@ee.tamu.edu](mailto:ehsani@ee.tamu.edu)

# Contents

---



- Background
- Advanced Mobile integrated Power System (AMPS)
- AMPS features
- AMPS Architecture
- Load Analysis
- Component operating characteristics and modeling
  - Engine
  - Alternator system
  - Fuel cell system
  - Batteries
  - Ultracapacitors
- Modeling and simulation—System Level
- Conclusion

# Background

---



## ● Introduction

- At present, most automobiles use 14V or 28V DC electrical systems. However, the ability of this system in meeting the needs of future loads is questionable.
- The need for improvement in comfort, convenience, entertainment, safety, security, communications, and environmental concerns necessitates the need for improved electrical power systems.
- Concept of More Electric Vehicles (MEV)
  - With increasing electrical loads, conventional vehicles are becoming more and more electric.
  - Increasing electrical power systems instead of mechanical, hydraulic, and pneumatic power transfer systems is a dominant trend.
  - Demand for higher fuel economy and reduced emissions will push the industry to seek electrification of ancillaries and engine augmentation.
- The proposed 42V PowerNet electrical system will facilitate high power future loads and enable the introduction of power electronics.

# Background

---



## ● History of the automotive power systems

### ● Up to 1912

- Electrical systems had been used only in the ignition and lighting systems.

### ● Invention of electric starter in 1912

- First electric self-starter automobile was introduced.

### ● 1912-1955

- Development of the generator was coincidental with the electric starter.
- Keeping the batteries charged using the charging system.

### ● By the late 1950s

- The change from 6V to 12V system had been made in almost all the automobile companies.

### ● Since 1960

- Electrical power requirements have been steadily increasing, which is motivating the introduction of a higher system voltage, i.e., 42V.

# Background



## ● Conventional automotive electrical systems

- Energy storage system
- Charging system
- Cranking system
- Ignition system
- Lighting system
- Instrumentation system
- Electric machines
- Electronic loads

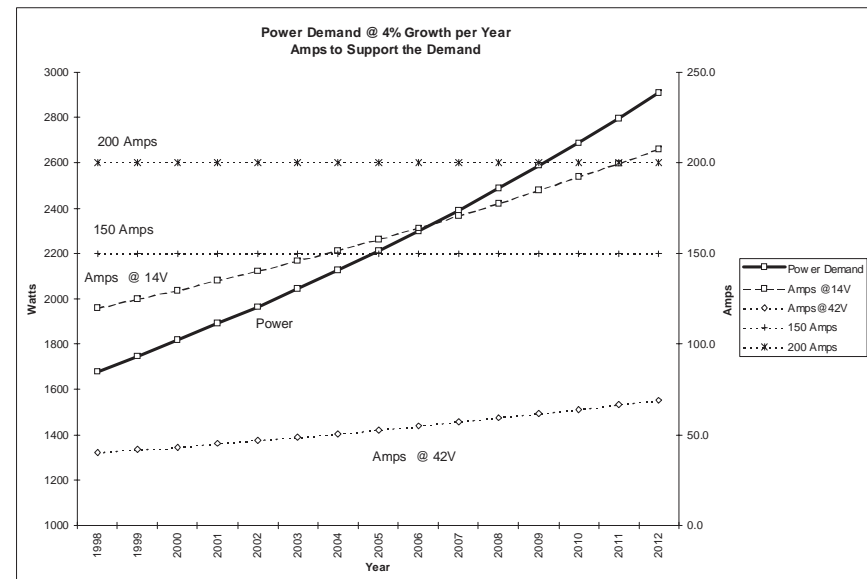

# Future Electric Power System



## ● Powering up a higher system voltage

- Increasing electrical loads in the MEV necessitates a higher system voltage, such as the proposed 42V, to cope with the greater loads.
- Main disadvantages of the low voltage system:
  - Increased size, weight, and cost of the vehicle wiring. (Chart on wiring complexity trend)
  - Higher ohmic losses in wiring harnesses, connections, switches and relays, commutators and brushes, and power semiconductors.
  - Higher temperature and need for improved cooling.
  - Lower distribution system performance. (Chart on wire gauge distribution)

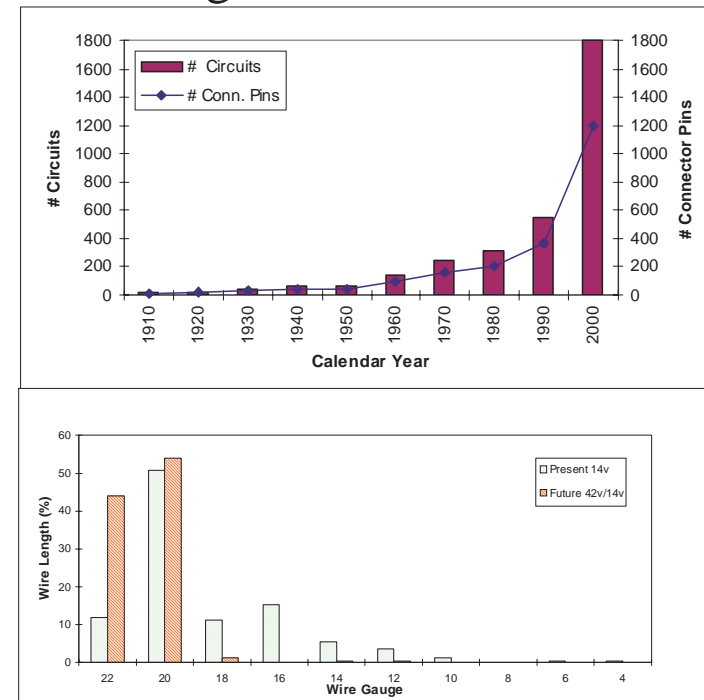

# Background

---



- Increasing electric loads in military vehicles
  - Except for the conventional electric loads: lights, pumps, fans, etc. more and more electric loads are needed to meet the multi-mission requirements including:
    - Cabin climate conditioning
    - Vehicle control and actuation (engine, transmission control, electric steering, active suspension etc.
    - Military mission related loads, (reconnaissance, detection, communication, silent watch, high power laser and microwave equipments and weapons etc)
  - Clearly, simply increasing the power capacity of conventional power system to meet these requirements will result in very bulky, heavy, low efficiency system, even useless to meet the requirements

# Advanced Mobile integrated Power System (AMPS)

---



## ● Electrical distribution system architectures

### Conventional distribution systems:

- Widely varying system voltage (9V to 16V).
- Destructive high voltage transients - particularly load dump.
- Loads are designed to operate at the lowest voltage. Therefore, at higher voltages they draw more current leading to requirement of overrated loads.
- Load-dump protection is distributed among all electronic modules.
- High losses in the brushes of motors at 12V.
- Proliferation of connectors and connector types.
- Expensive and time consuming assembly process, fault tracing, and repairing.

# Background

---



## ● Conventional automotive electrical systems

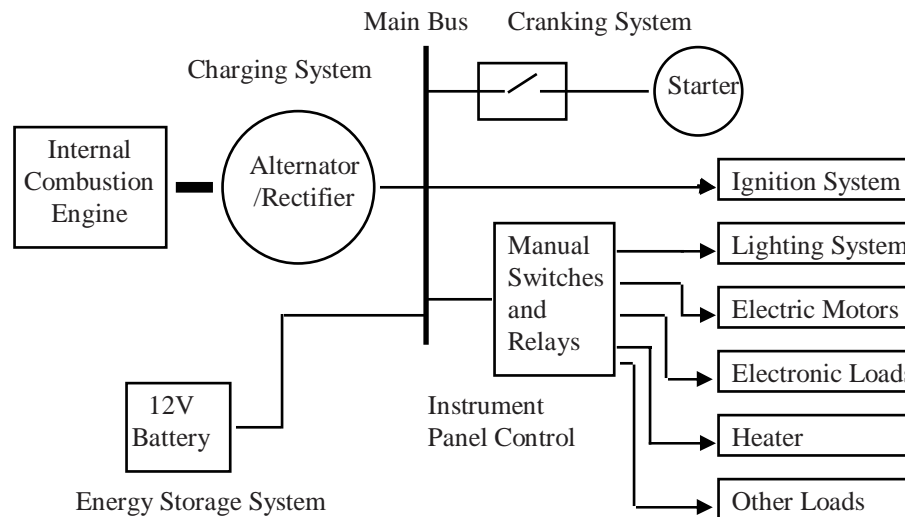

Conventional 14V DC distribution system architecture

# Advanced Mobile integrated Power System (AMPS)

---



- Advanced electrical distribution system architectures
  - Multiplexed architectures with separate power and communication buses.
  - Using intelligent remote modules. Therefore, the number and length of wires in the harness are reduced.
  - Power Management System (PMS) whose primary functions are:
    - Battery management and charging strategy in a multiple battery system.
    - Load management.
    - Management of the alternator including the regulator.
    - Provision and control of a high integrity supply system.
  - Hybrid multi-voltage level system to supply power to different AC and DC loads at different levels is possible.

# Advanced Mobile integrated Power System (AMPS)



## ● Power Management System (PMS)

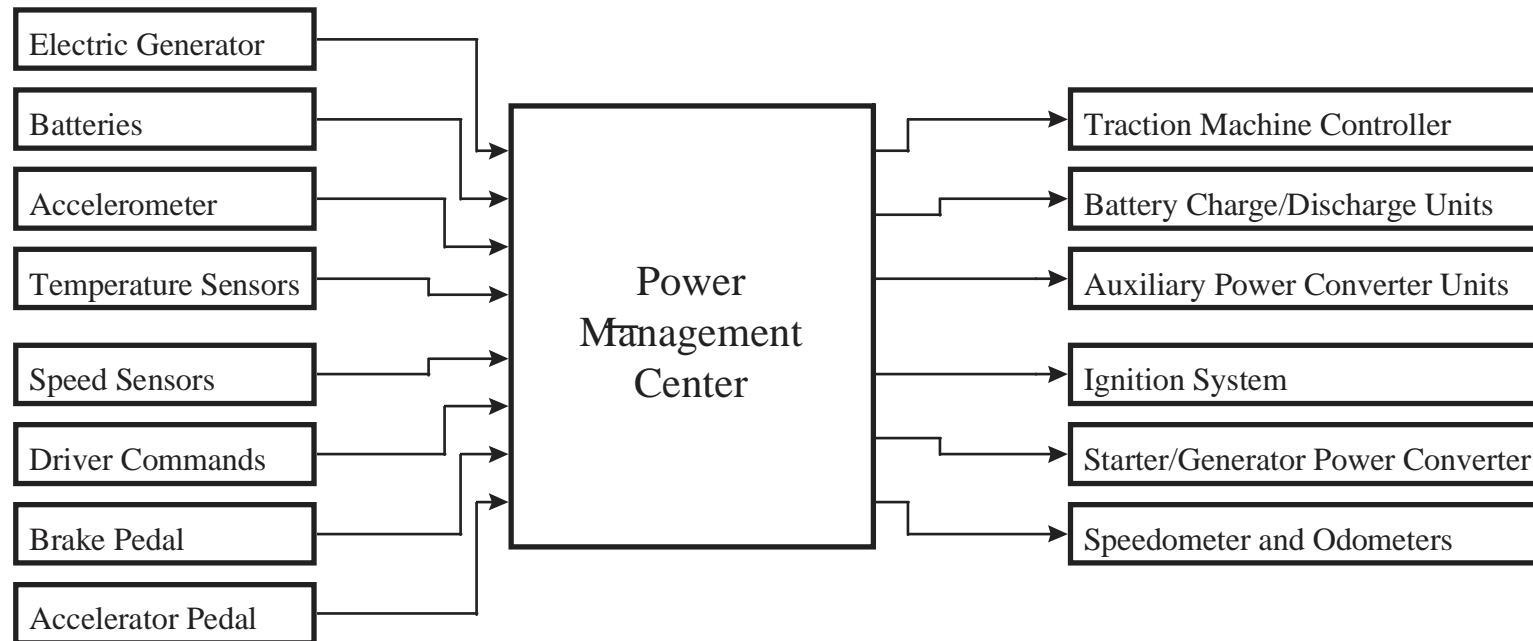

# Advanced Mobile integrated Power System (AMPS)



## Advanced electrical distribution system architectures

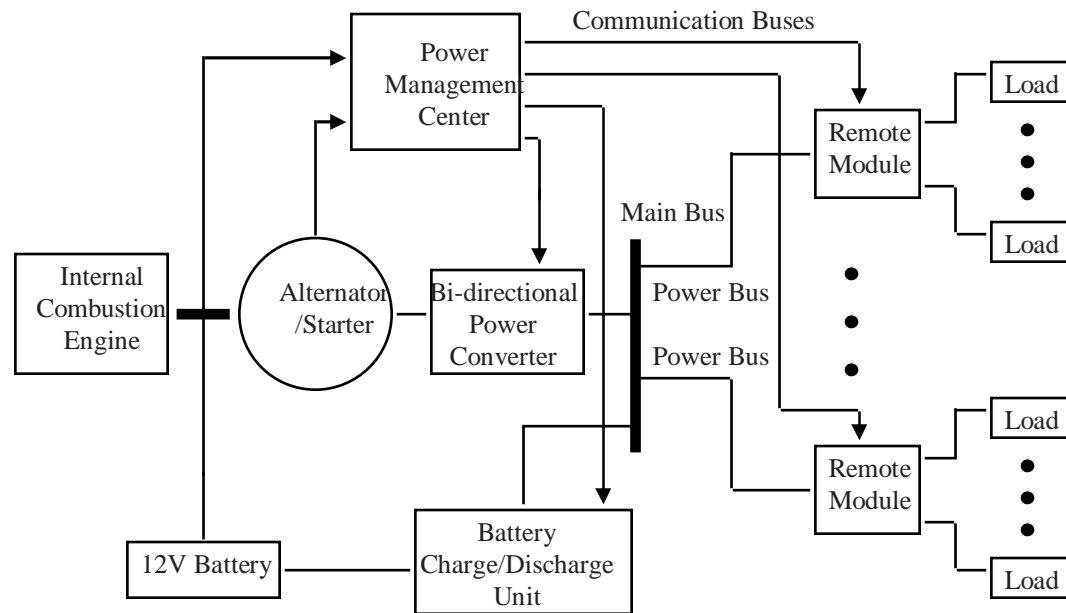

Advanced multiplexed automotive power system architecture of the future with power and communication buses.

# Advanced Mobile integrated Power System (AMPS)



- The role of electronics and microprocessors in advanced automotive electrical systems

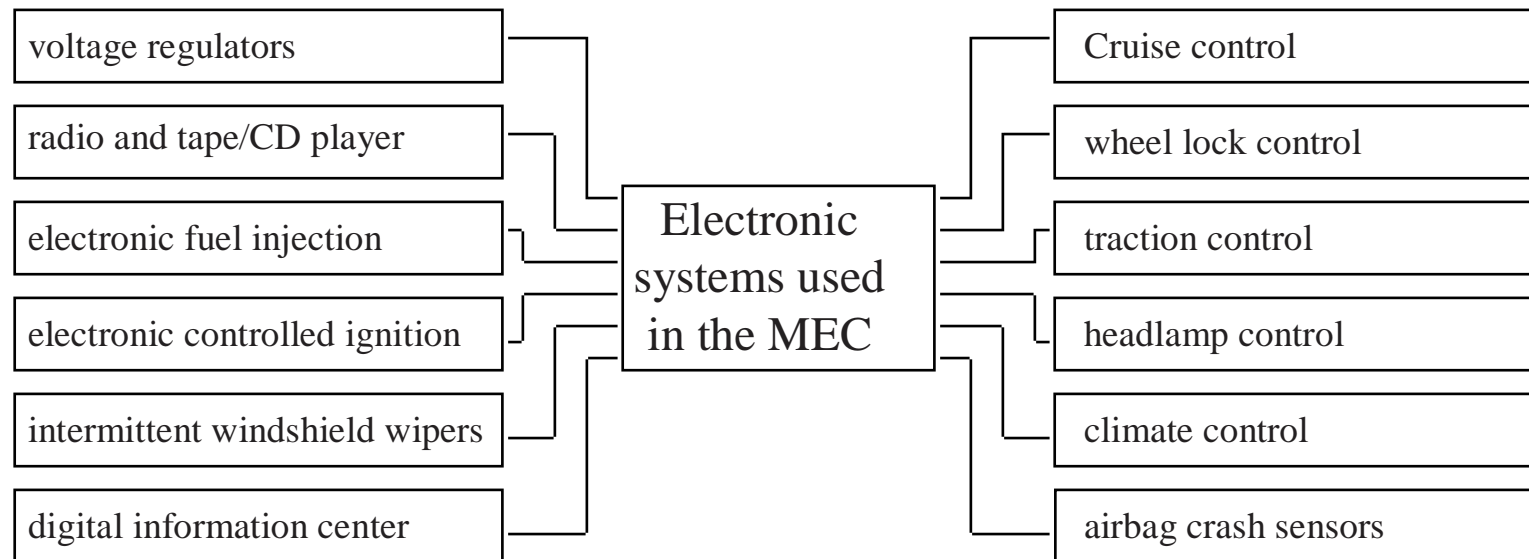

# Advanced Mobile integrated Power System (AMPS)



## HEV Power Transfer Systems

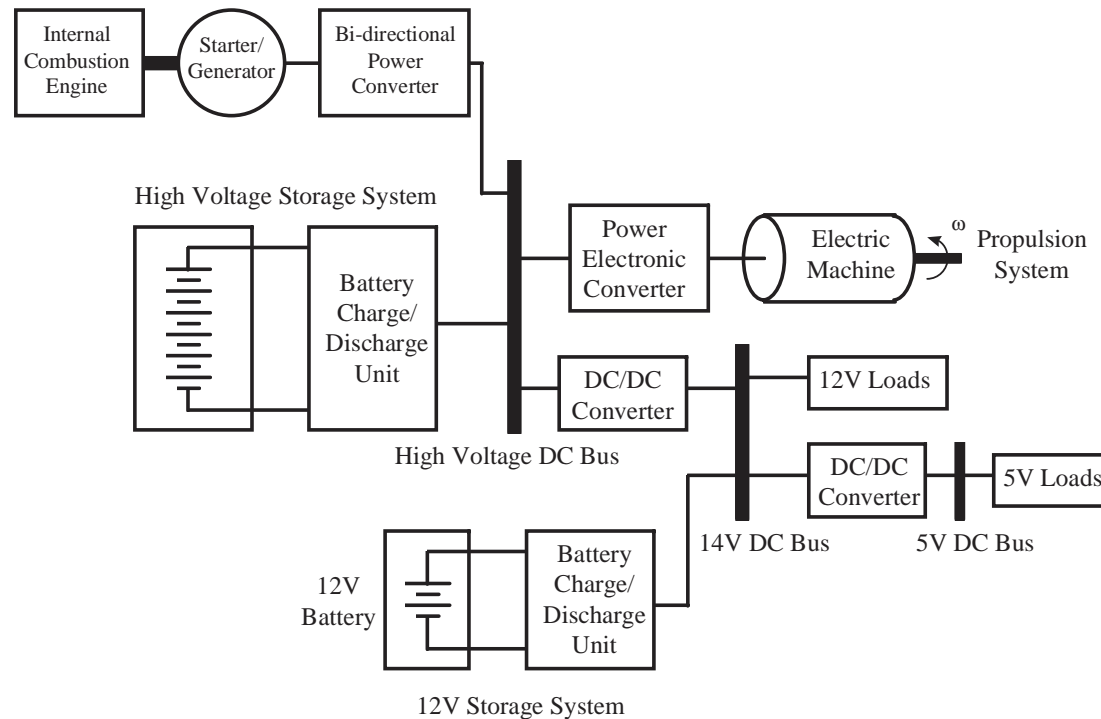

Conventional electrical power distribution system architecture for hybrid electric vehicles

# Advanced Mobile integrated Power System (AMPS)



## ● EV & HEV Power Transfer Systems

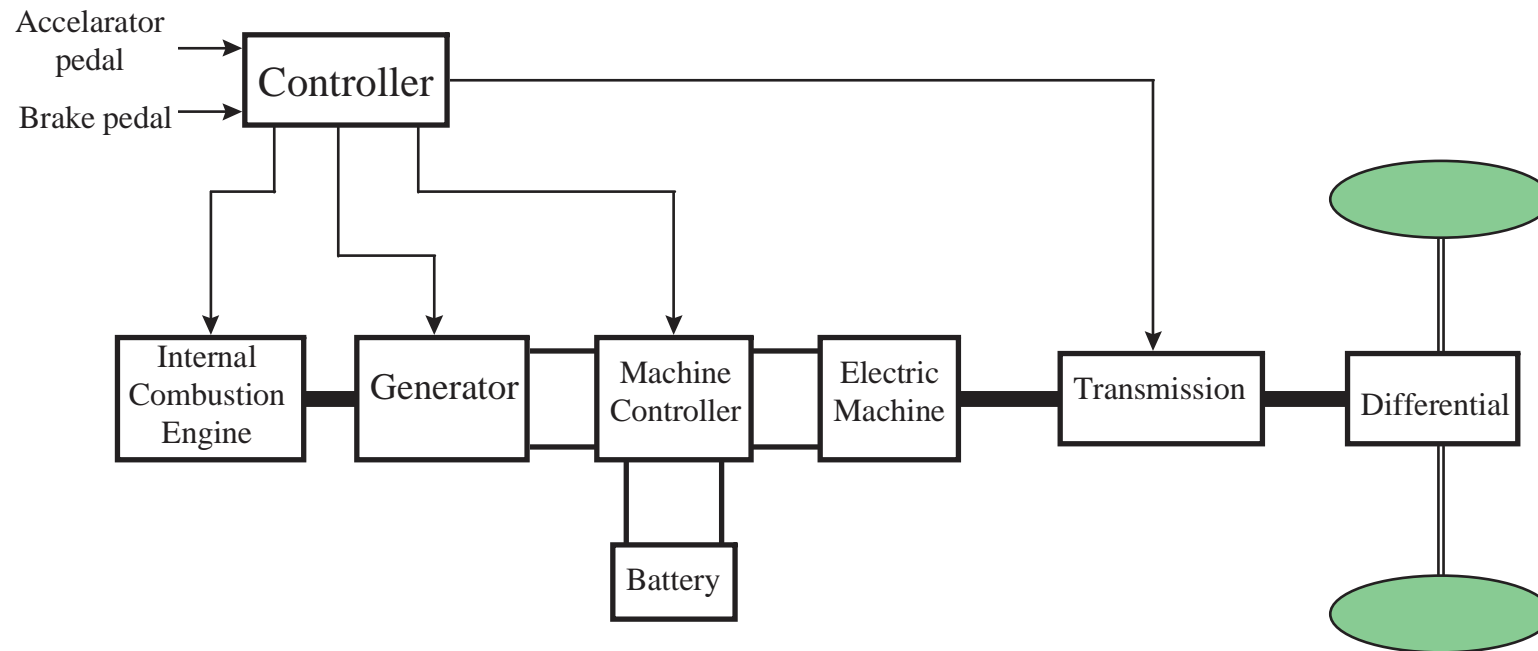

Series HEV architecture

# Advanced Mobile integrated Power System (AMPS)



## ● EV & HEV Power Transfer Systems

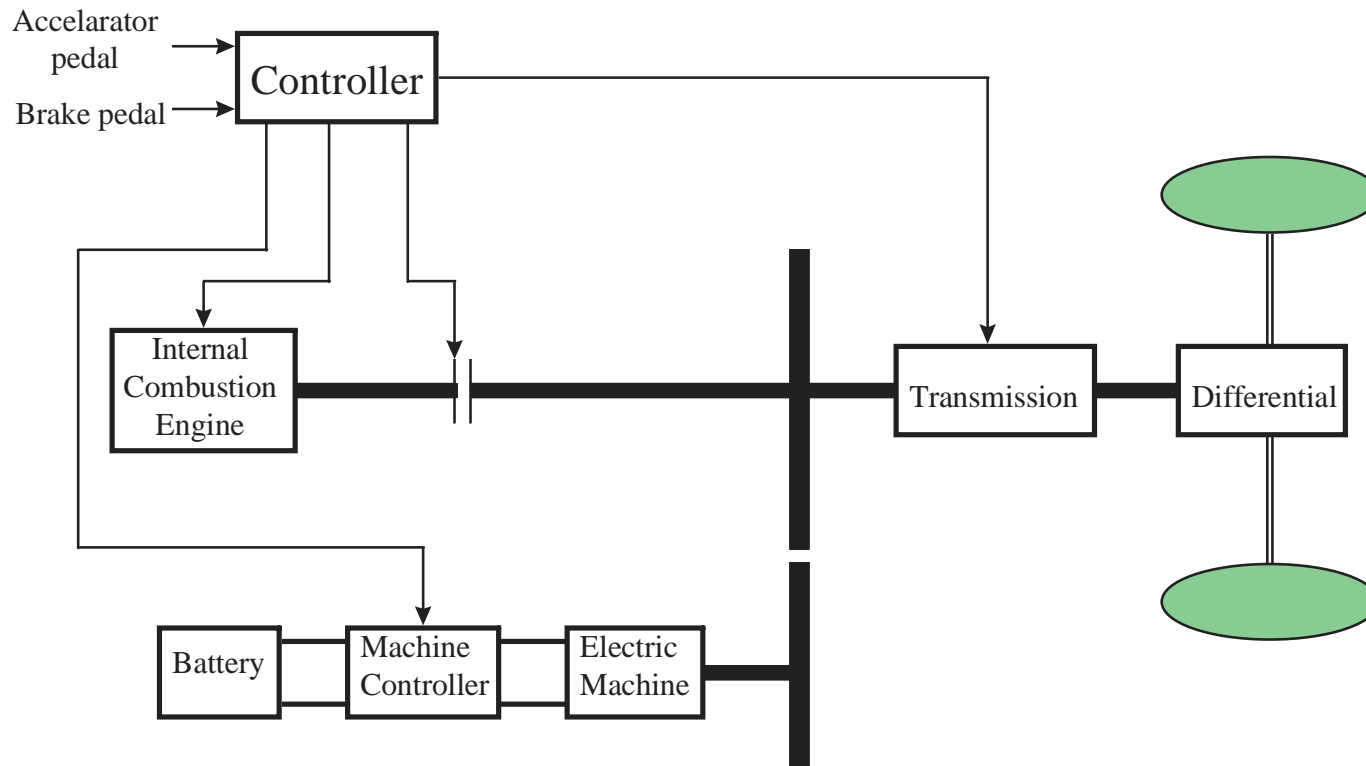

Parallel HEV architecture

# Advanced Mobile integrated Power System (AMPS)

---



- Network based power system
  - Power generating, storage and distribution network:
    - Controllable power flow routes
  - Information and control signal network:
    - Control the power flow accordingly, including
      - Control commands input ports, operating modes and statues display,
      - Microcontroller based control center (power management)
      - Control Logic and strategy
      - Control actuation

# AMPS Features

---



- Multi-(hybrid) power source---energy source and power source
  - The energy source (alternator, fuel cells etc.) supplies the total energy with mild and relatively stable power output.
  - The power source (batteries, ultracapacitors etc.) supplies peak power in short period to meet the high power pulsed load
- Multi-voltage to feed different voltage loads
- Turn-on and turn-off of each individual power source optionally
- Controllable power output of each individual power source
- Turn-on and turn-off of all the individual loads
- Self-protection: limit the power to the safe region, and if the load power is too large for the power source, turn off the the loads with lower priority
- Real time operating modes and status monitoring and displaying

# Advanced Mobile integrated Power System (AMPS)



## Dual voltage automotive power system---power network

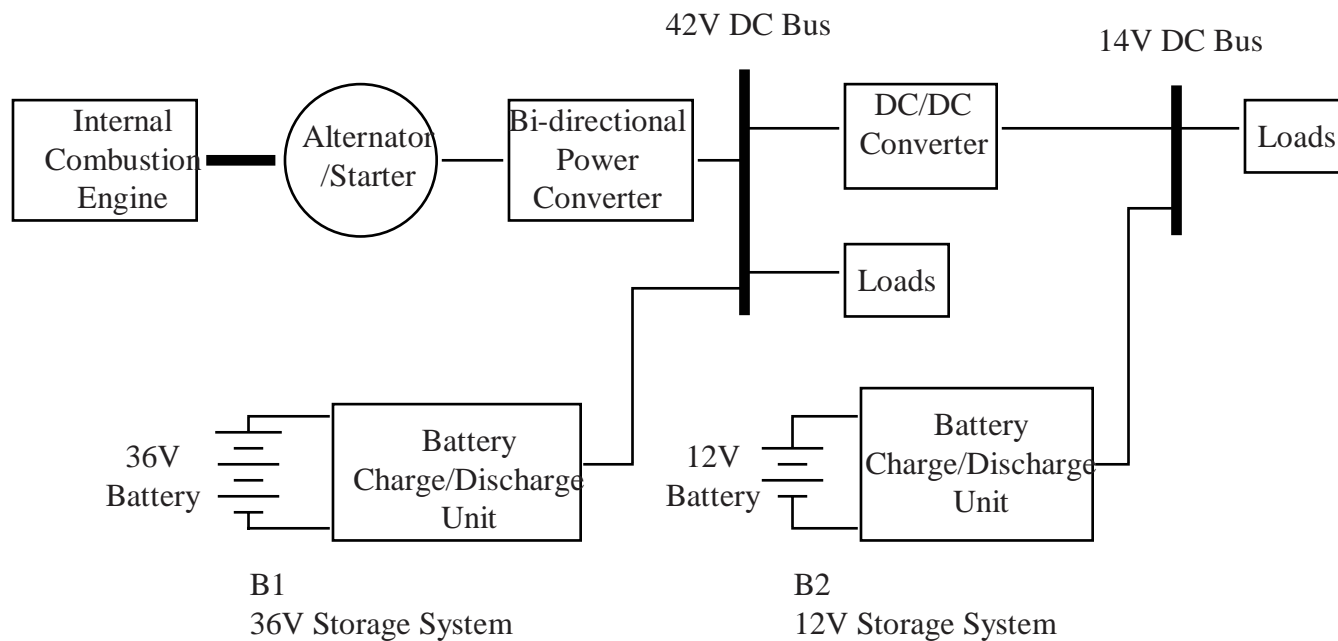

The concept of a dual voltage automotive power system architecture of the future.

# AMPS Architecture



- Structure of the overall power system

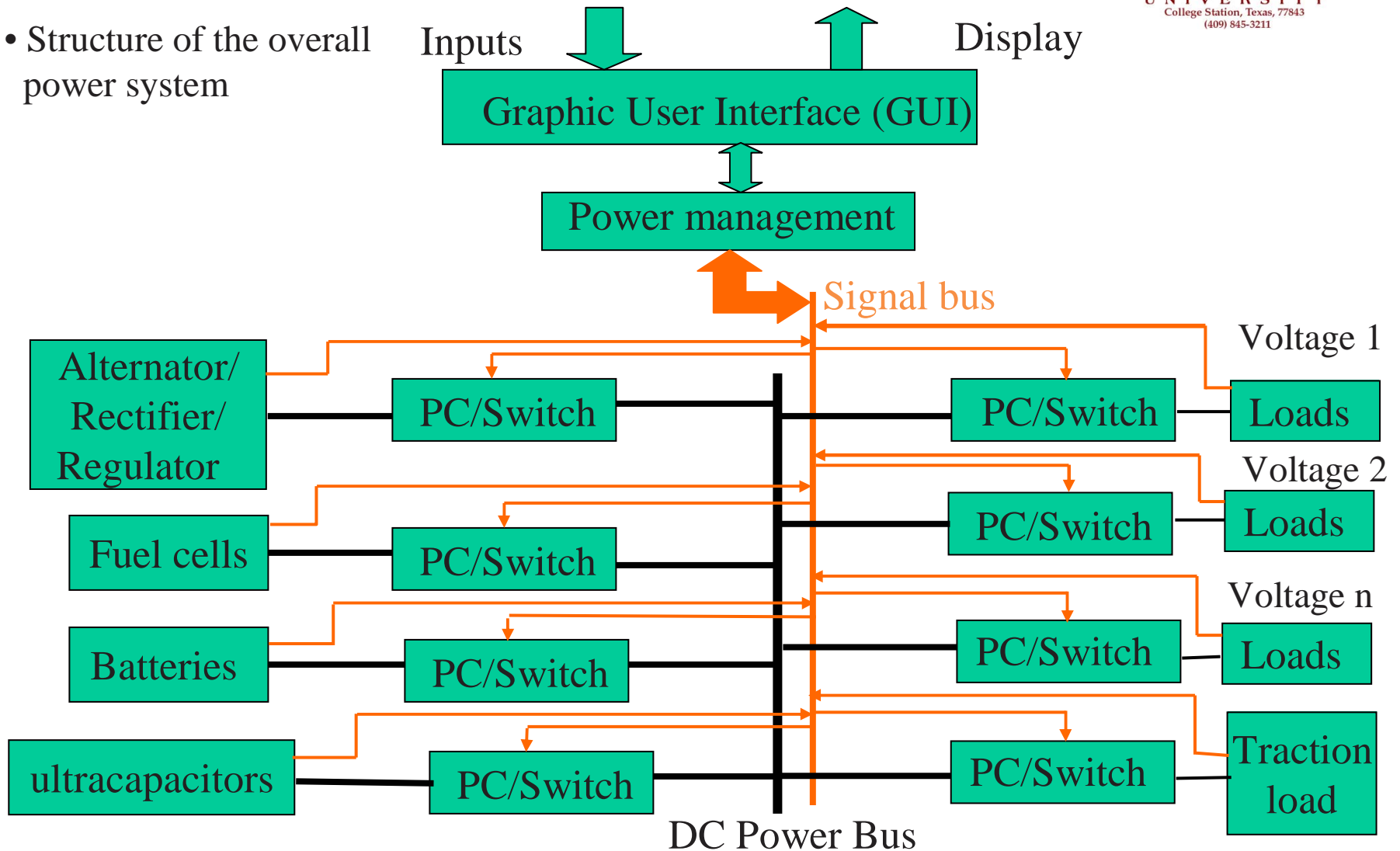

# AMPS Architecture

---



- Power network
  - A common power DC Bus
  - All the power sources are connected to the DC bus through power converter (PC)/switches
  - The PC/switches control the power flow from the power sources, according to the control signal from the signal BUS
  - The loads with different voltages are connected to the power DC bus through PC/switches
  - The PC/switches regulate the DC Bus voltage to match the load voltages and control the power flow to the loads and turn-on or turn off the loads from the DC bus

# AMPS Architecture

---



- Signal (information) network or CAN (controllable Area network)
  - A common signal Bus transferring signals
  - all the operating and status signals access the signal bus with priority flags and identification number (ID)
  - A microprocessor based power management (PM) acts as the control center
  - The PM can access the signal bus to receive the operating signals of the power sources and loads
  - The PM makes the decision to control power sources and loads by sending Signal to the signal bus
  - The power sources and loads controllers (PCs) control the power flow accordingly

# AMPS Architecture

---



- Power Management
  - Gather all the operating information and control commands
  - Make control decisions to each individual power source and load
  - Generate control signals
  - Deliver the control signals to the signal bus

# AMPS Architecture

---



- Graphic User Interface (GUI)
  - Transfer the user's commands to the power management
  - Graphically Display the system operating modes, status and important parameters

# AMPS Architecture

---



- The system described above is a smart, self-adaptive, self-protecting and actively self-controlled power system
- It needs many power electronics for controlling the power flow from the power source
- Lots of power electronics increase the cost, perhaps the complexities caused by thermal management

# AMPS Architecture



- Parallel connected power network

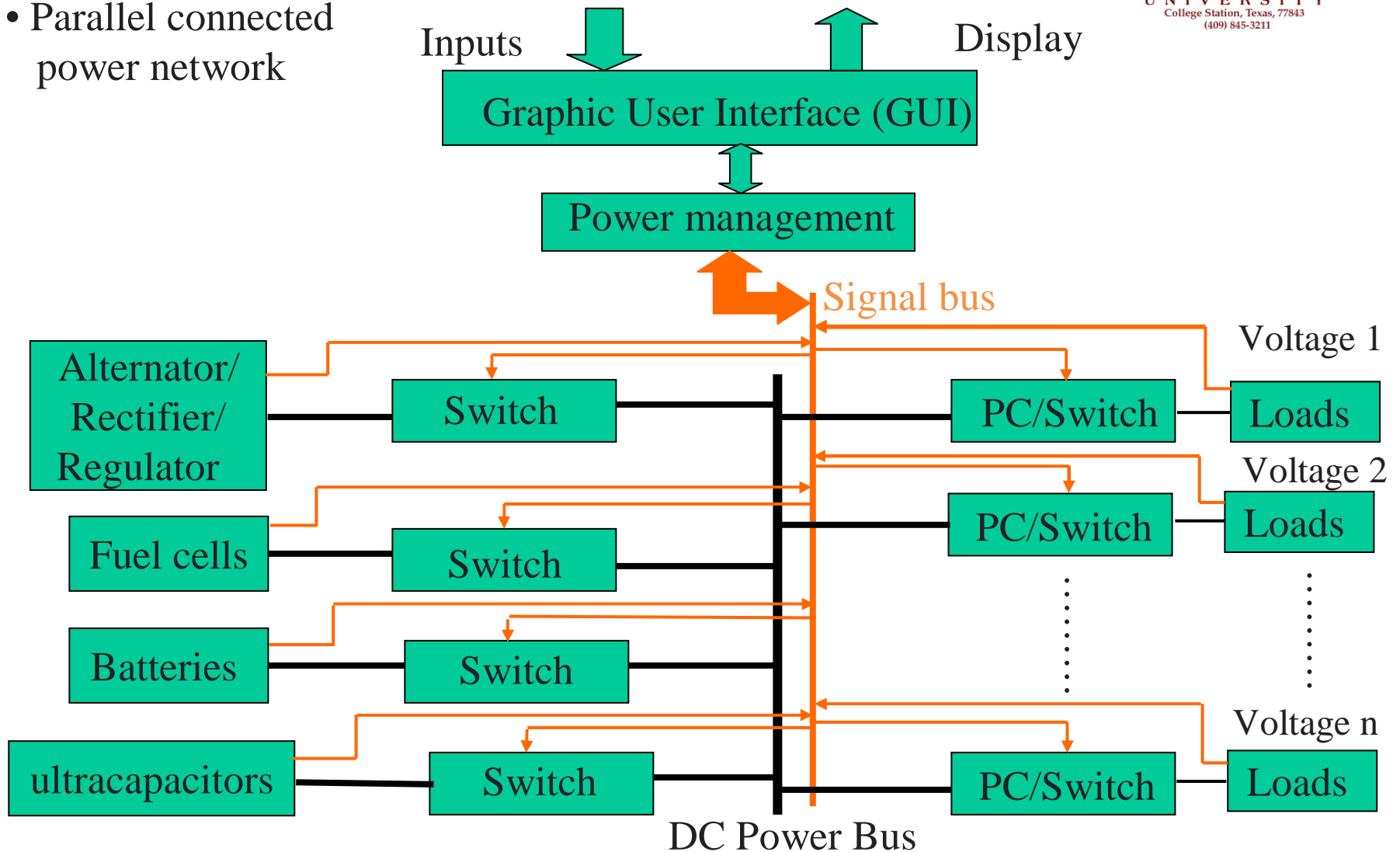

# AMPS Architecture

---



- Parallel connected power network
  - All the power sources are connected to the DC Bus through switches
  - The switches are used to connect or disconnect the power source to from DC bus.
  - The switches may be electrically controlled solenoids
  - The power from each individual power source is the natural response of that unit to the DC bus voltage
  - Control the DC bus voltage by controlling the load power, thus, indirectly controlling the power from the power sources
  - Delicate design of the power sources and the loads may achieve high performance, simple system

# Load Analysis

---



- Generally, the loads can be categorized as
  - Constant, continuous load with relatively small power, such as vehicle auxiliary loads, cabin climate conditioning, reconnaissance(?), detection(?) Etc.
  - Slow varying load with relatively small peaks, such as electrical power steering, active suspension, communication(?) etc.
  - Pulsed loads with very large magnitudes, such as, laser, microwave, electrical weapons etc.

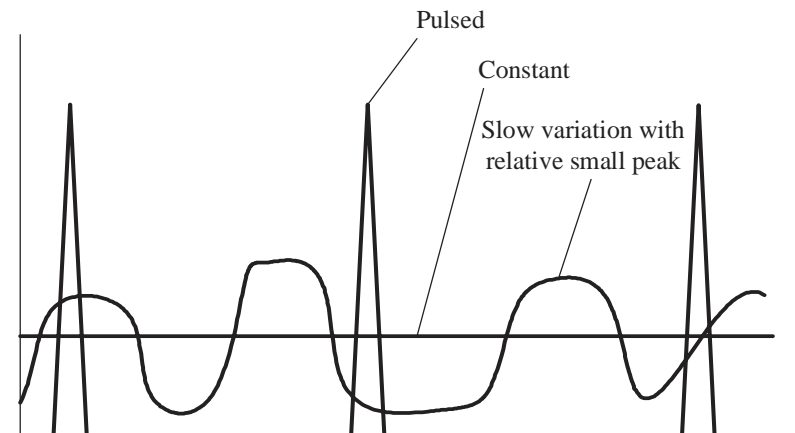

# Load Analysis

---



- The alternator and fuel cells may take care of the constant continuous loads
  - The batteries and ultracapacitors may take care of the slow varying loads
  - A pulse forming system may be needed to take care of the pulsed loads
- 
- Accurate analysis of the load characteristics is the base of the power system design and control

# Power Source Operating Characteristics and Modeling

---



- Due to the complex and multi-power source characteristics, one of the most important issues in the system design and development is to fully understand the operating characteristics of each individual power source.
- Building a model to each power source with reasonable complex level will be very helpful to to the design overall system, inducing
  - The power ratings design of all the power sources,
  - Control strategy design of the overall system

# Modeling---Components

Texas A&M

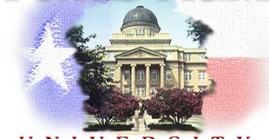

UNIVERSITY  
College Station, Texas, 77843  
(409) 845-3211

- Compression ignition (diesel) engine

- Fuel/ air ratio  $F / A = Th \times (F / A)_{\max}$

Th---throttle, Max.=1

$(F/A)_{\max}$ ---Fuel/air ratio at fuel load

- Volumetric efficiency  $\eta_v = f(N)$

N---Engine rpm

- Indicated mean effective pressure:

$$mep_i = Q_L \times (F / A) \times \eta_i \times \eta_v \times m_u$$

$Q_L$ ---fuel low heating value,  $\eta_i$ ---ideal converter efficiency

$M_u$ ---Air mass flow per cycle per unit liter of cylinder

- Indicated torque:  $T_{ind} = mep_i \times V_d / 4\pi$

$V_d$ ---total volume of cylinders

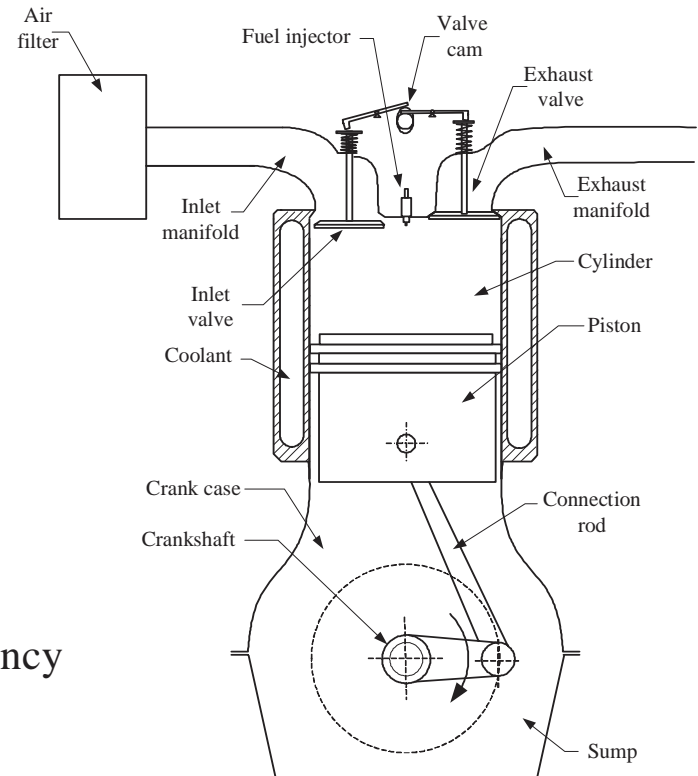

# Modeling---Components

Texas A&M

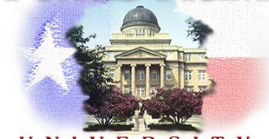

UNIVERSITY  
College Station, Texas, 77843  
(409) 845-3211

- Compression ignition (diesel) engine

- Brake torque:  $T_b = T_{ind} - T_f$

$T_f$ ---Total friction torque, a function of N

- Brake Power:  $P_b = T_b \times N / 9549$

- Fuel flow per hour:

$$F_f = (A/F) \times \dot{m}_a \times 3600$$

$\dot{m}_a$  ---air mass flow per second

- Brake specific fuel consumption:

$$g_e = F_f / P_b$$

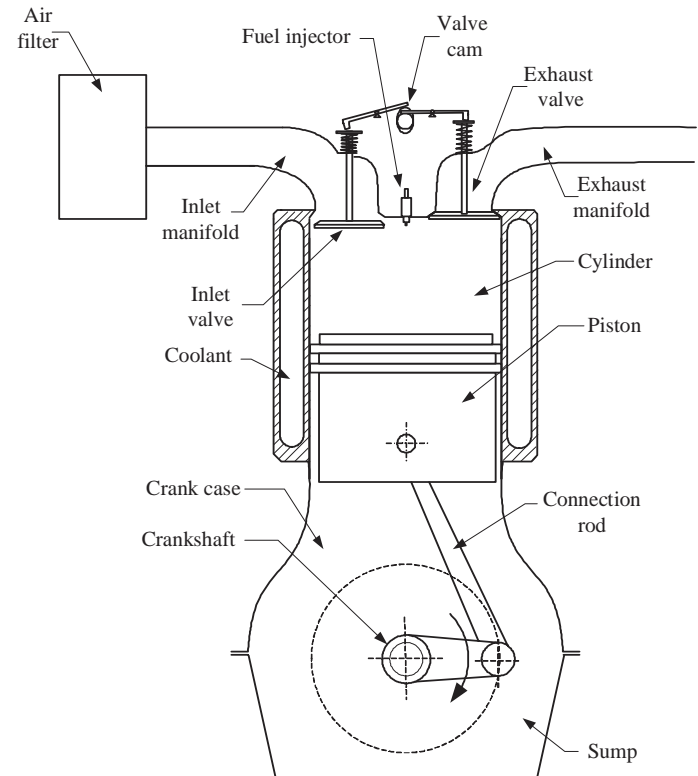

# Modeling---Components



- Compression ignition (diesel) engine (simulink model)

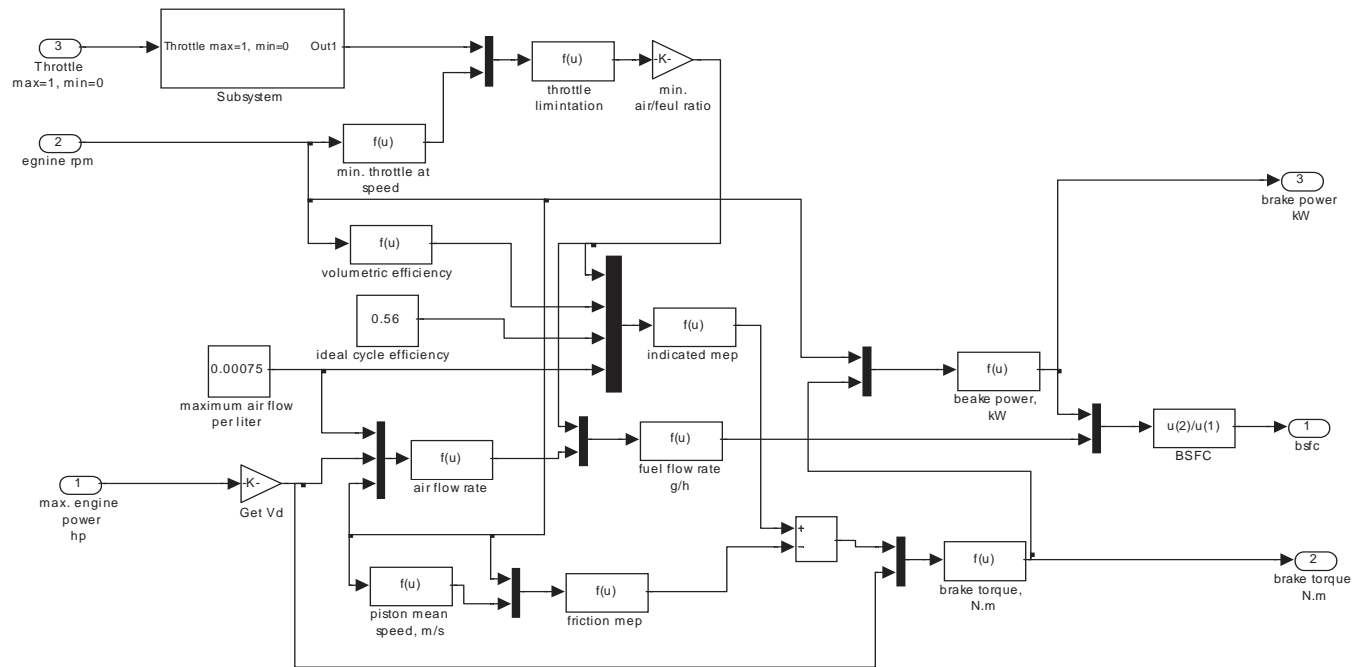

# Modeling---Components



- Compression ignition (diesel) engine full throttle characteristics

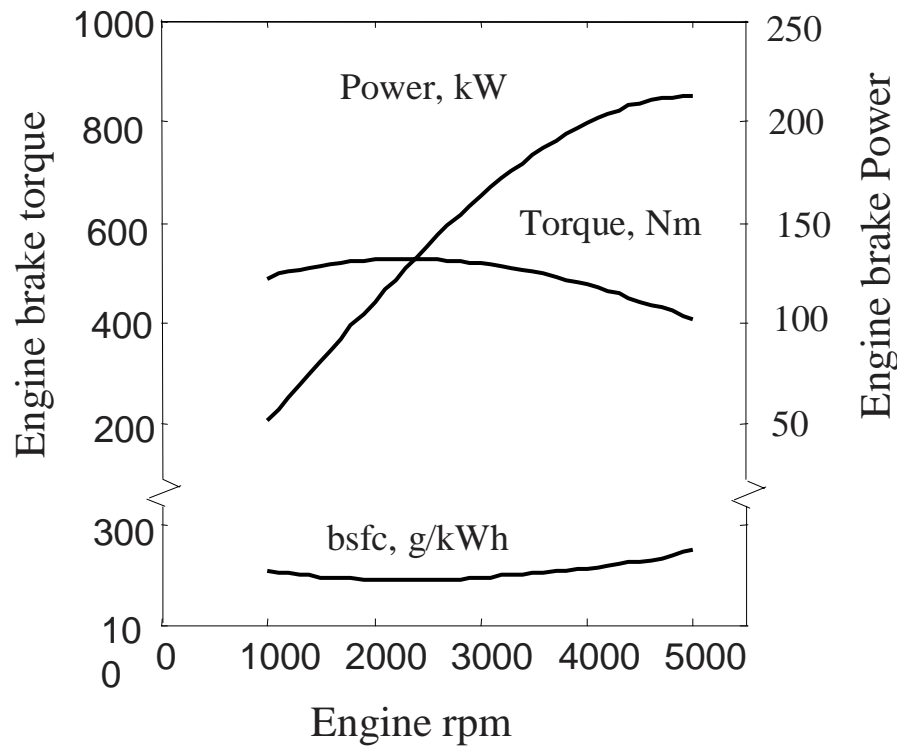

# Modeling---Components



- Engine Modeling is less important than other components due to:
  - Engine is mainly used for traction
  - Only small fraction of its power going to the alternator
  - The load variation in alternator has very small influence on the engine operating
- However, alternator modeling needs the engine rpm as the input.
- By a vehicle traction model, the engine speed can be obtained as

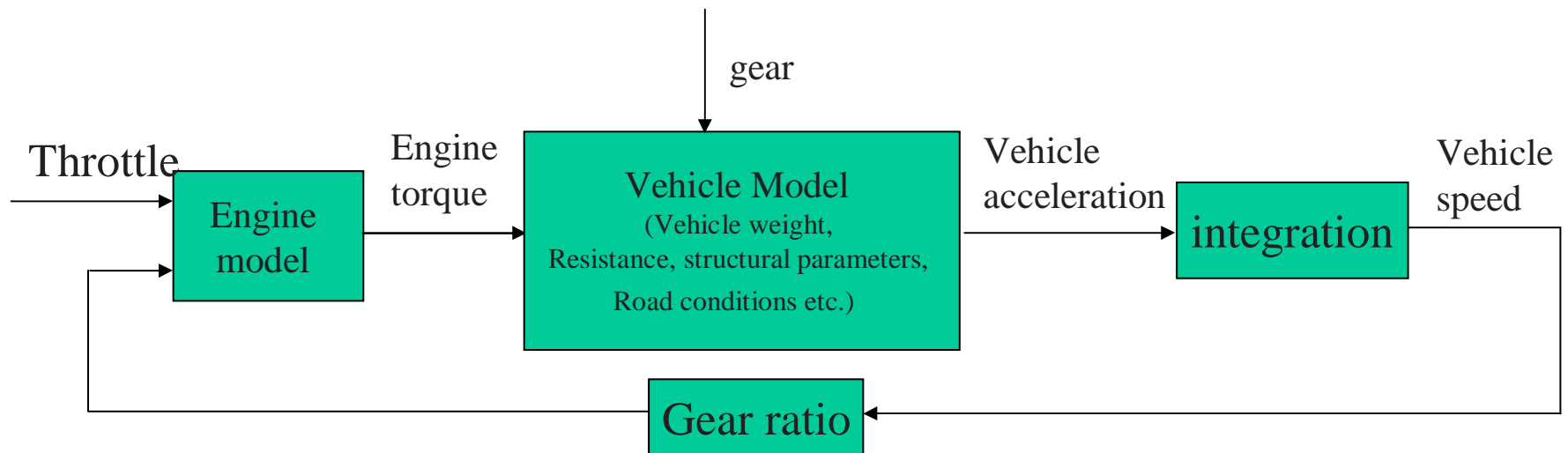

# Modeling---Components

---



- Establishing a vehicle traction model to obtain engine speed needs great effort and beyond our present scope
- Regarding our power system simulation , the engine speed may be estimated as follows:
  - Engine rpm is proportional to the vehicle speed
  - When vehicle speed is zero, engine speed is set at its idle (minimum) rpm
  - When vehicle is maximum , the engine rpm is maximum.

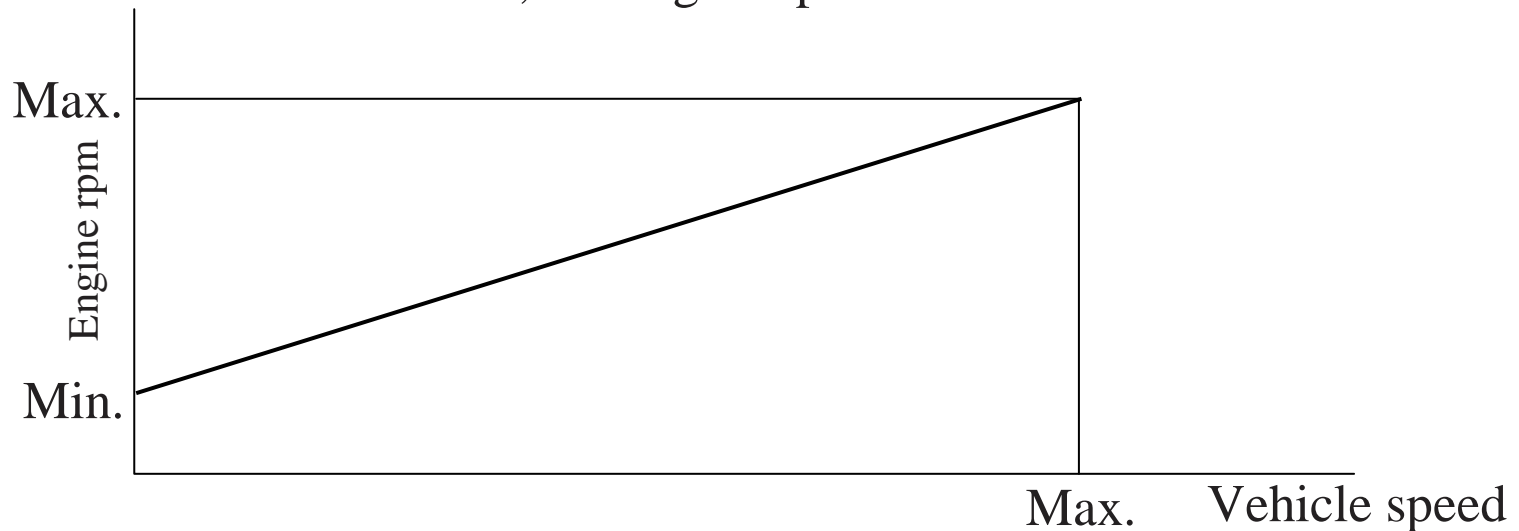

# Modeling---Components



- Alternator system modeling
  - Alternator system includes alternator, rectifier and voltage regulator

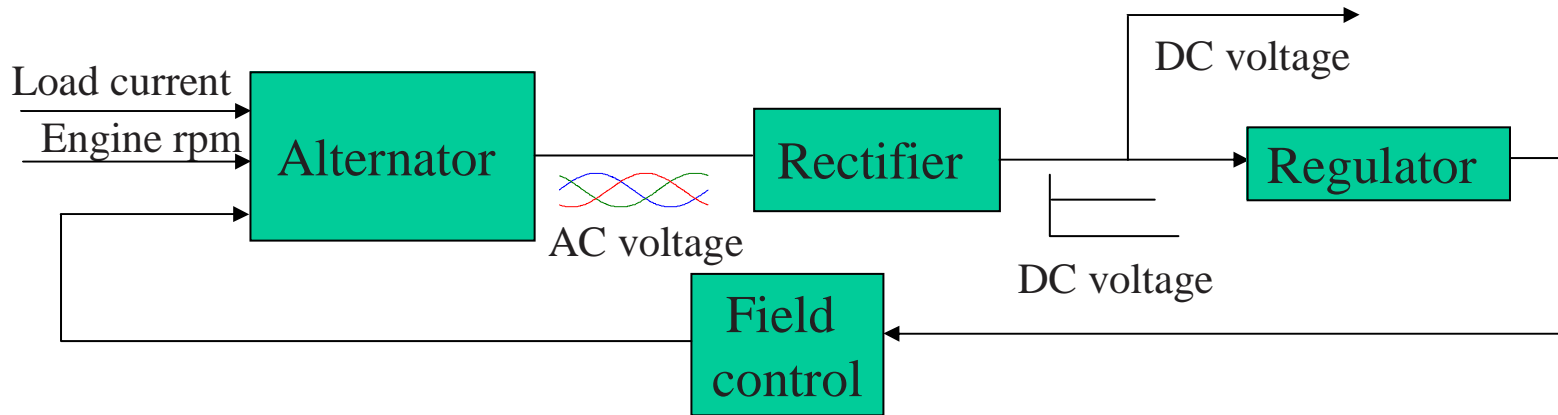

# Modeling---Components

---



- Alternator modeling
  - Basically, the alternator modeling is based on the equation of

$$V_t = k_\phi N - Ri$$

$k_\phi$ --- coefficient of back emf, a function of field current  $I_f$

$N$ ---alternator rpm

$R$ ---stator winding resistance

$i$ --- load current

# Modeling---Components



- Alternator modeling

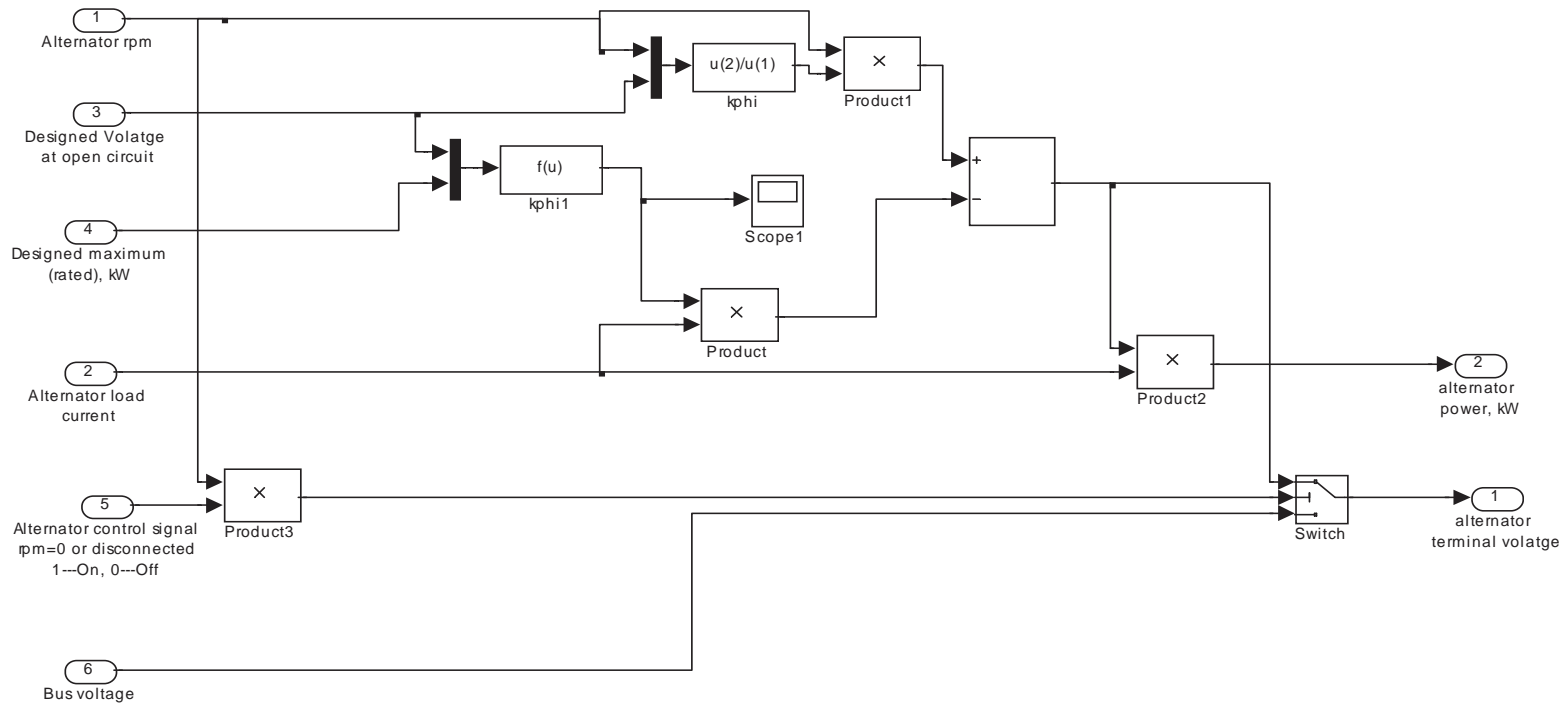

# Component Characteristics and Modeling

---



- **Fuel cells**

- Various types of fuel cell systems and their characteristics

System	Properties
Phosphoric acid fuel cells (PAFCs)	Operating temp. 60-200°C, liquid electrolyte
Alkaline fuel cells (AFCs)	Operating temp. 100°C, liquid electrolyte
Proton exchange membrane fuel cells (PEMFCs)	Operating temp. 60-100°C, solid electrolyte
Direct methanol fuel cells (DMFCs)	Operating temp. 100°C, solid electrolyte
Molten carbonate fuel cells (MCFCs)	Operating temp. 500-800 °C, liquid electrolyte
Solid Oxide fuel cells (SOFCs)	Operating temperature 1000-1200 °C

# Component Characteristics and Modeling



## • Fuel cells

### • Proton Exchange Membrane fuel cell (PEMFC)

#### Advantages:

- Low operating temperature
- Solid electrolyte (Thin plastic membrane)
- Simple construction
- High fuel efficiency (over 50%)
- Zero Emissions

#### Disadvantages:

- Need pure hydrogen as fuel
- Hard to store pure hydrogen on board
- valuable metal (Pt, Platinum) is needed as the catalyst

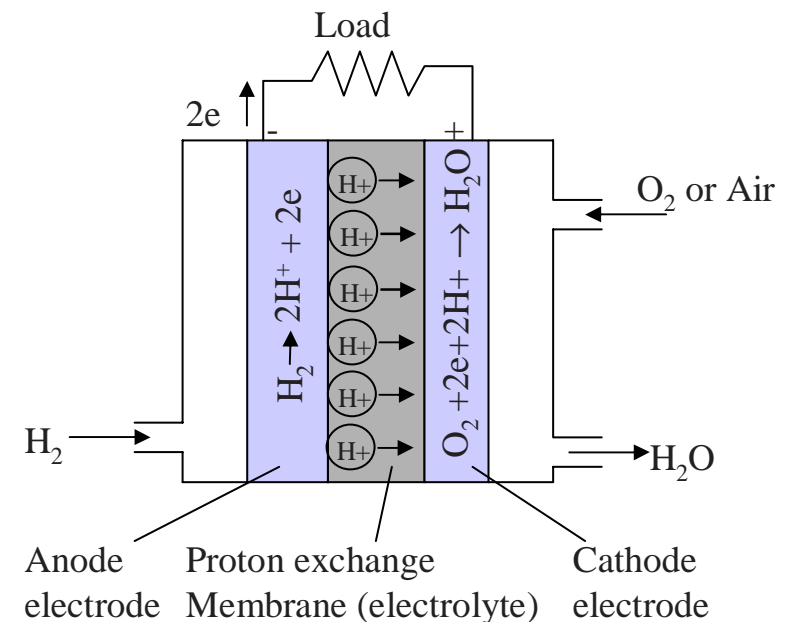

# Component Characteristics and Modeling



- Proton Exchange Membrane Fuel Cell (PEMFC) System

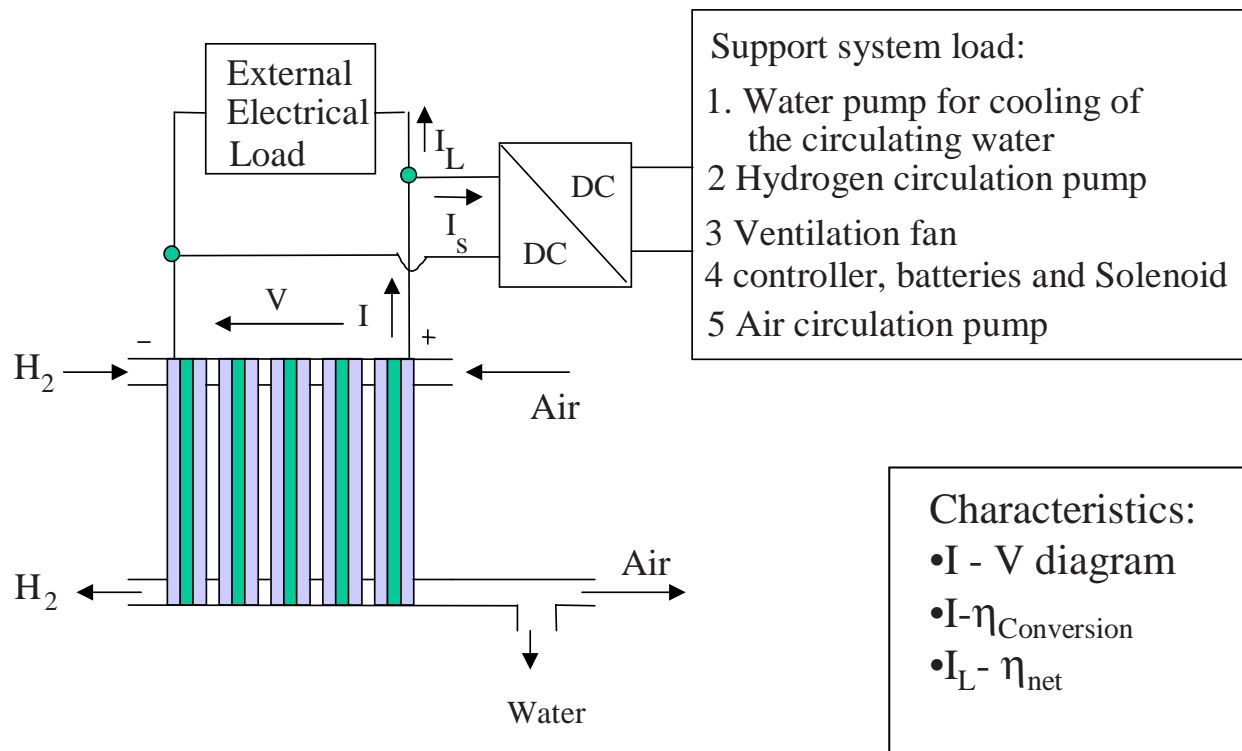

# Component Characteristics and Modeling

---



- **Fuel cell stack operating characteristics**

- $H_2-O_2$  (air) fuel cell has a reversible voltage of 1.23V
- Practical open circuit voltage is around 0.9 to 1V.
- With increasing current, the voltage has a significant drop
- Generally, modeling this voltage-current characteristics is based on chemical and thermal analysis with some empirical data,
- More often modeling method is curve fitting, when experimental data are available

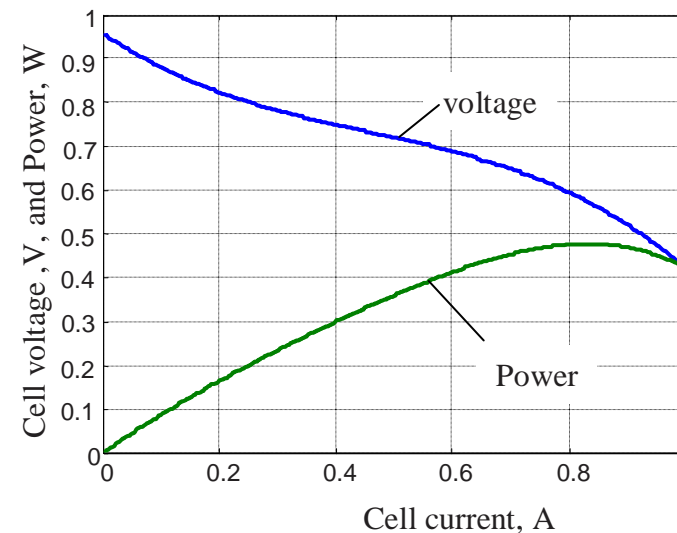

# Component Characteristics and Modeling

---



- Modeling of auxiliary power of fuel cell system
  - Auxiliaries of a fuel cell system includes water pump, hydrogen circulating pump ventilation fan and air compressor
  - Air compressor power takes most of the auxiliary power and is usually the only concern. It can be expressed as

$$P_{ac} = \frac{\gamma}{\eta_c(\gamma-1)} RT \frac{\dot{m}_a}{W_a} \left[ \left( \frac{p}{p_0} \right)^{\frac{\gamma-1}{\gamma}} - 1 \right]$$

$\gamma$ — specific heat ratio, 1.4 for air,  $R$ —gas constant,  $T$ —inlet temperature,  $K^\circ$   
 $\dot{m}_a$ —air mass flow rate g/s,  $W_a$ —molecular weight of air,  
 $p$ —outlet pressure,  $p_0$ —inlet pressure,  $\eta_c$ —compressor and driving motor efficiency

- Air mass flow rate is proportional to the hydrogen mass flow rate, and proportional to the load current

# Component Characteristics and Modeling



- Fuel cell system modeling

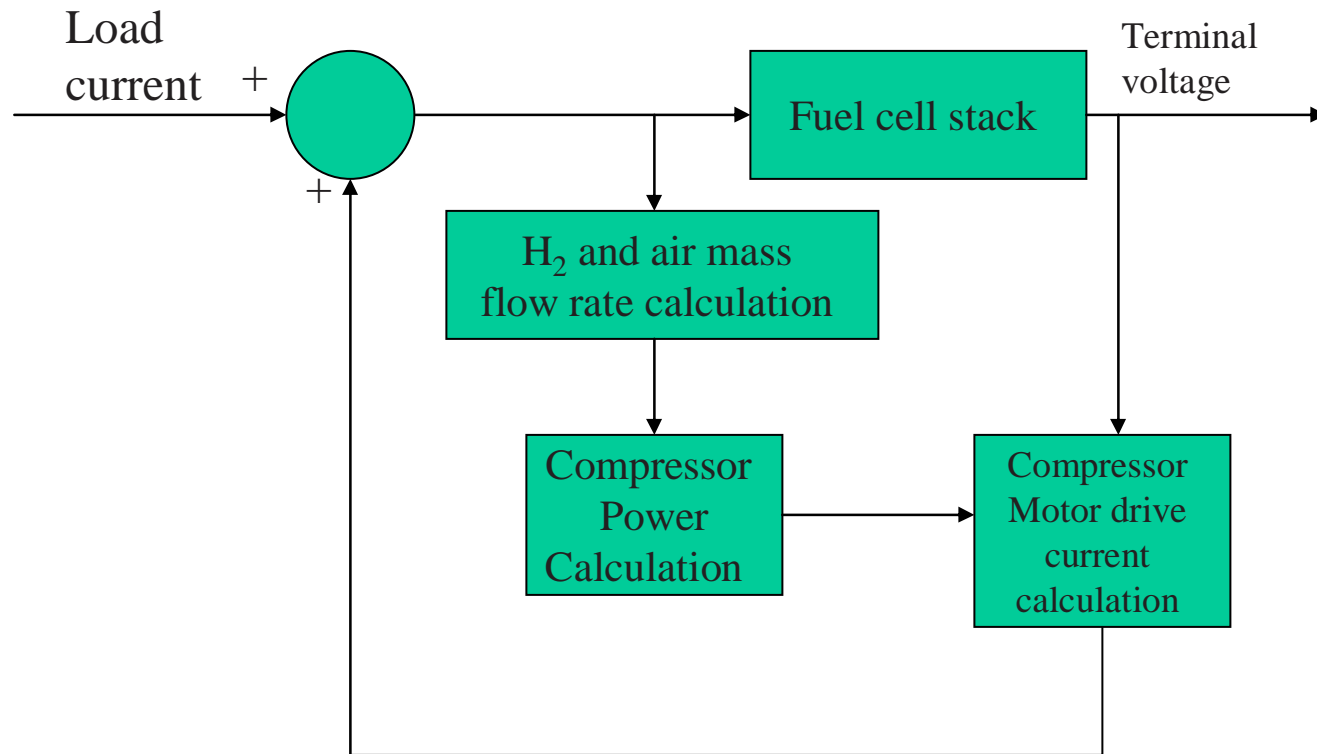



# Component Characteristics and Modeling



- Fuel cell system modeling (simulink Model)

Simulated operating characteristics of a 3 kW, 28 V open circuit voltage system

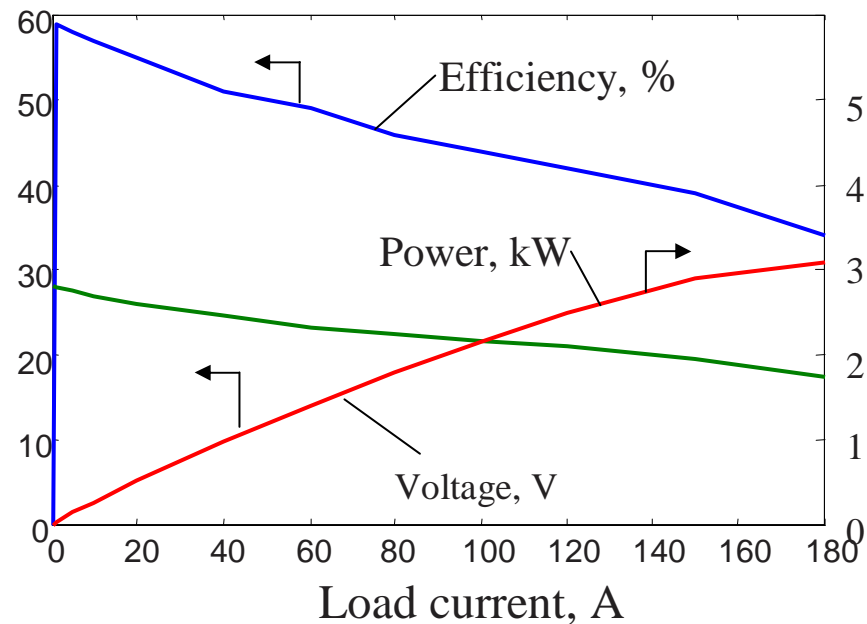

# Component Characteristics and Modeling

---



- **Chemical batteries**

Typical battery characteristics\*

<b>Batteries</b>	<b>specific energy W.h/kg</b>	<b>peak power W/kg</b>	<b>energy efficiency(%)</b>	<b>cycle life</b>
Lead/acid	35-50	150-400	>80	500-1000
Nickel/Cadmium	40-60	80-150	75	800
Nickel/iron	50-60	80-150	75	1500-2000
Nickel/Zinc	55-75	170-260	70	300
Nickel/metal	70-95	200-300	70	750-1200+
Sodium/sulfur	150-240	230	85	800+
lithium/iron/sulfide	100-130	150-250	80	1000+

\* Reference, D.A.J. Rand et el Batteries for electric vehicles, Research studies Press,Ltd, 1998

# Component Characteristics and Modeling



- Battery model
  - The battery is modeled based on its electrical, instead of chemical properties
  - The open circuit voltage  $E_0$  is a function of battery state-of-charge (SOC)
  - A resistor  $R_{int}$  varying with SOC emulates the chemical reaction resistance
  - A resistance,  $R_c$ , with constant value emulates the ohmic resistance

$$V_{Load} = E_0(soc) - (R_{int}(soc) + R_c)I$$

$$P_{Load} = I E_0(soc) - (R_{int}(soc) + R_c)I^2$$

Where:  $R_{int}(soc)$  ---internal resistance of batteries  
 $R_c$ ---connection resistance

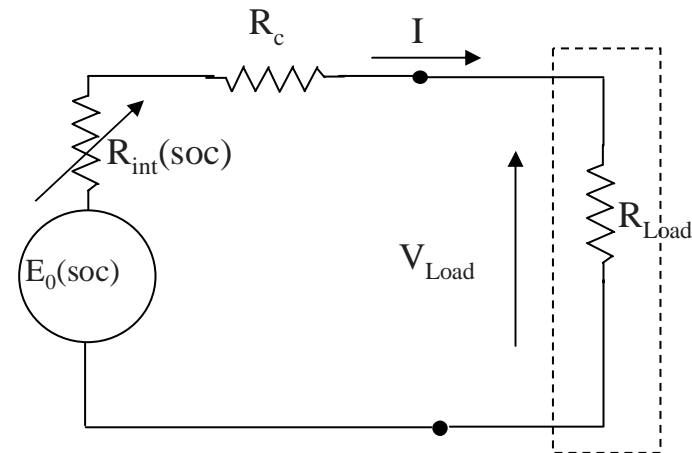

# Component Characteristics and Modeling



## • Battery simulink Model

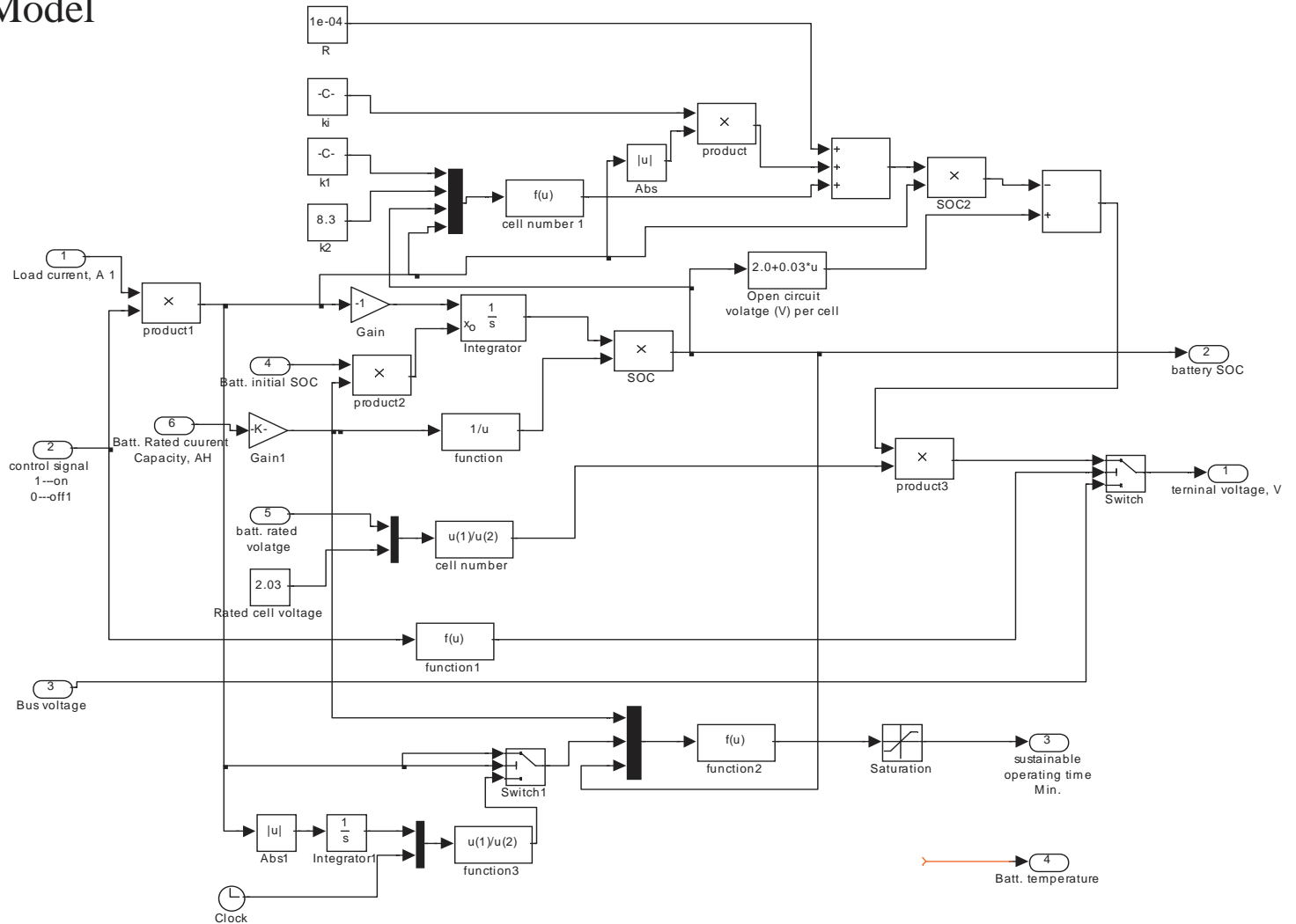
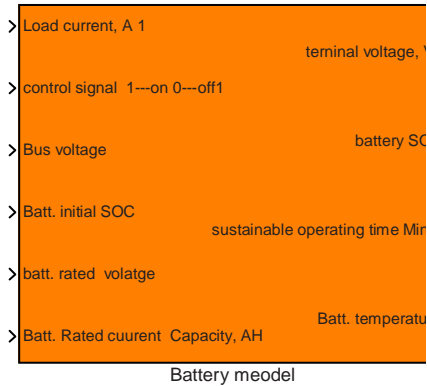

# Modeling---Components



- Battery model

Discharging characteristics

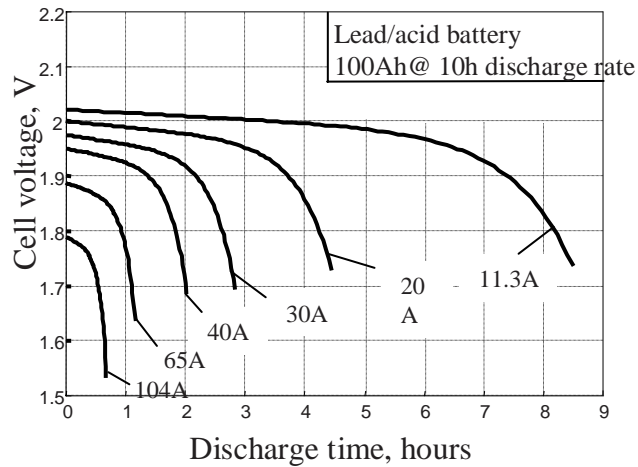

charging characteristics

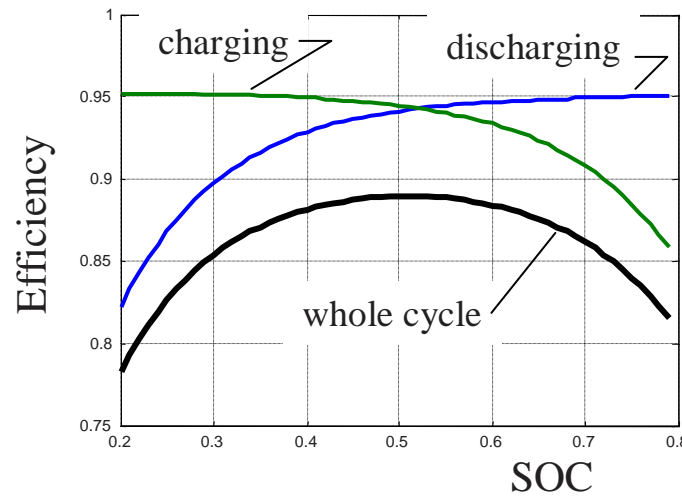
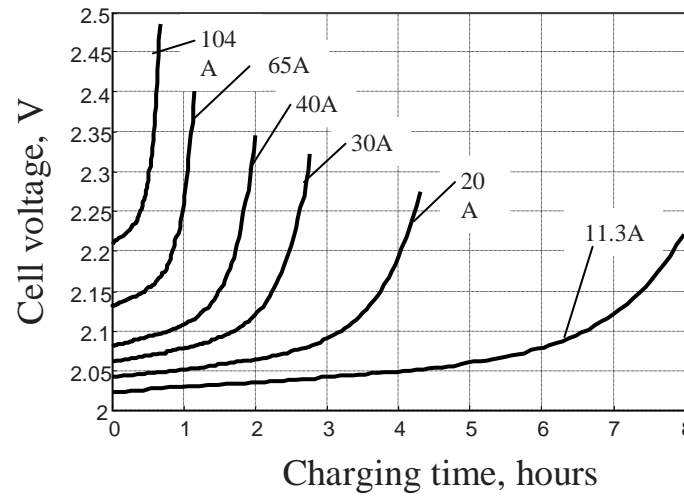

# Modeling---Components

---



- Battery model
  - The electrical property based model does not include the battery “memory” effect, and “capacity recovery” effect
  - This may cause error in estimating the remaining energy and and cause error in estimating the time that the battery can sustain operation.
  - These should be included in the later more accurate models

# Component Characteristics and Modeling

---



- **Electrical characteristics of chemical batteries**
  - ◆ **Low specific power density**
  - ◆ **Not properly fit for highly dynamic load**
  - ◆ **High peak load power would need bulky battery packs**
  - ◆ **Short life under high current discharge and charge**

# Component Characteristics and Modeling

---



## • Ultracapacitors

- Advantages:
  - Much higher specific power density than batteries  
Peak power can possibly reach 1000W/kg to 1500 W/kg
  - High cycle efficiency  
about 95% or more
  - much longer life than batteries  
infinite life with good production and under proper operation condition
- Disadvantages:
  - Low specific energy density  
only 3-5 W.h/kg, compared 30-40 W.h/kg for lead/acid batteries
  - Large variation of terminal voltage, depending on the state-of-charge

# Component Characteristics and Modeling



## •Ultracapacitors

### Characteristic data of a ultracapacitor

Rated capacitance (DCC, 25°C)	F	145
Capacitance tolerance	%	±20
Rated voltage	V	42
Surge voltage	V	50
Max. series resistance, SSR (DCC 25°C)	mΩ	10
Specific power density (42V)	W/kg	2900
Max. current	A	600
Max. stored energy	J	128,000
Specific energy density (42V)	Wh/kg	2.3
Max. Leakage current (12h, 25°)	mA	30
Weight	kg	15
Volume	L	22
Operating temperature	°C	-35 to +65
Storage temperature	°C	-35 to +65
Life time (25°C)	y	10 ΔC<20% of initial value ESR<200% of initial value
Cyclability (25°C, I=20A))		500,000 ΔC<20% of initial value ESR<200% of initial value

<http://www.montena.com>, Montena Components

# Modeling---Components



- Ultracapacitor model

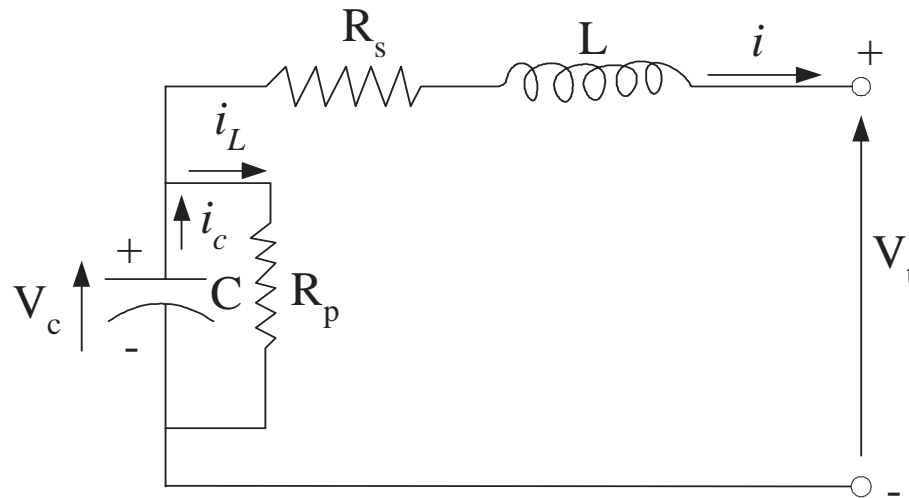

$$V_t = V_c - R_s i + L \frac{di}{dt}$$

$$V_c = V_c^0 - C \int_0^t i_c dt$$

$$i_L = \frac{V_c}{R_p}$$

$$i_c = i + i_L$$

# Modeling---Components



- Ultracapacitor model

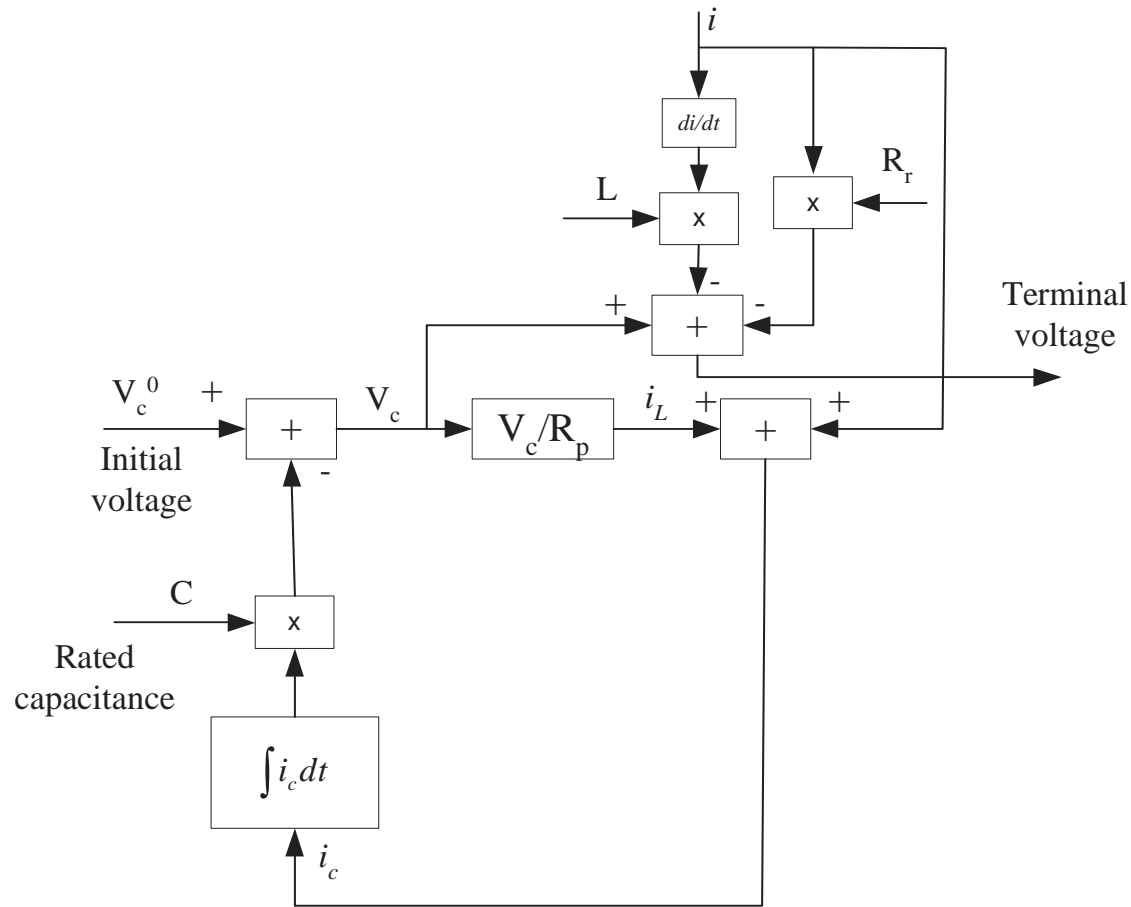

# Component Characteristics and Modeling



- Ultracapacitor model (simulink model)

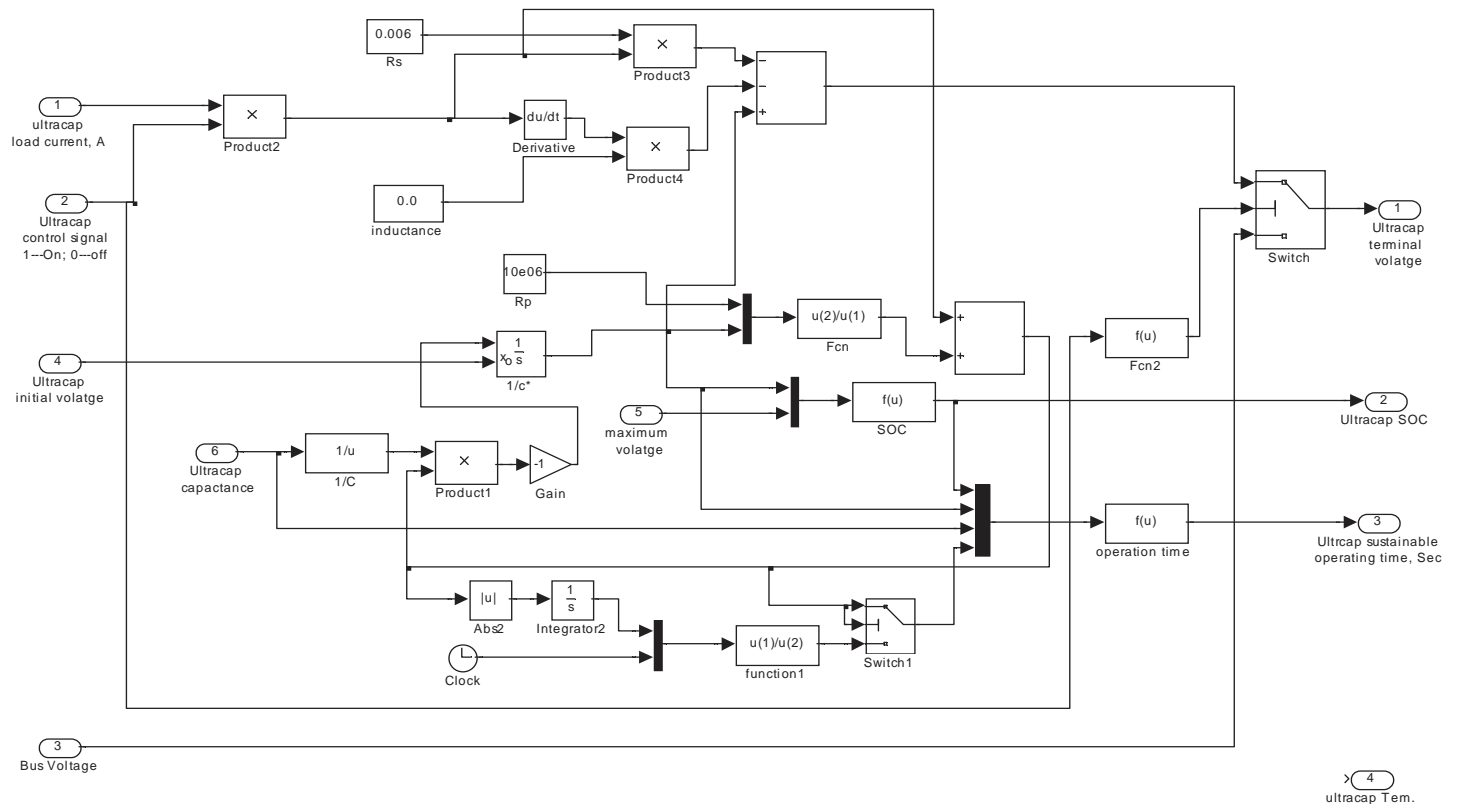
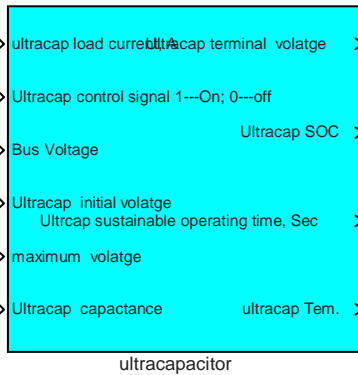

# Modeling---Components



- Ultracapacitor model (simulink model)

A single cell discharging characteristics

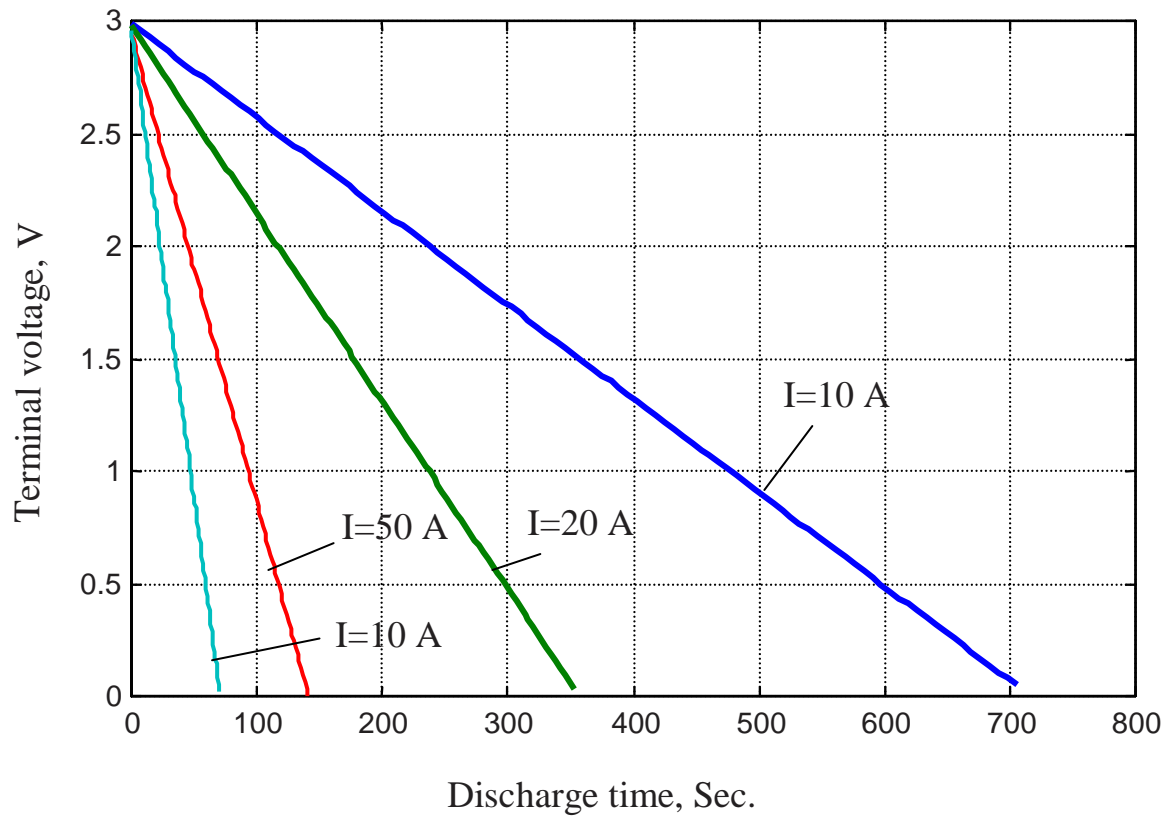

# Modeling---Power system

---



- Modeling design Strategy
  - Flexible Inputs:
    - System configuration option
    - Rated values of all the components
    - Initial conditions
    - User's commands (operation modes)
  - Graphic output:
    - Operation modes
    - Operation status (Battery SOC, temperature, reserve energy etc.)
    - Present operating parameters (Bus voltage, currents, etc.)

# Modeling and simulation --- System Level



- Modeling design Strategy (input and outputs)

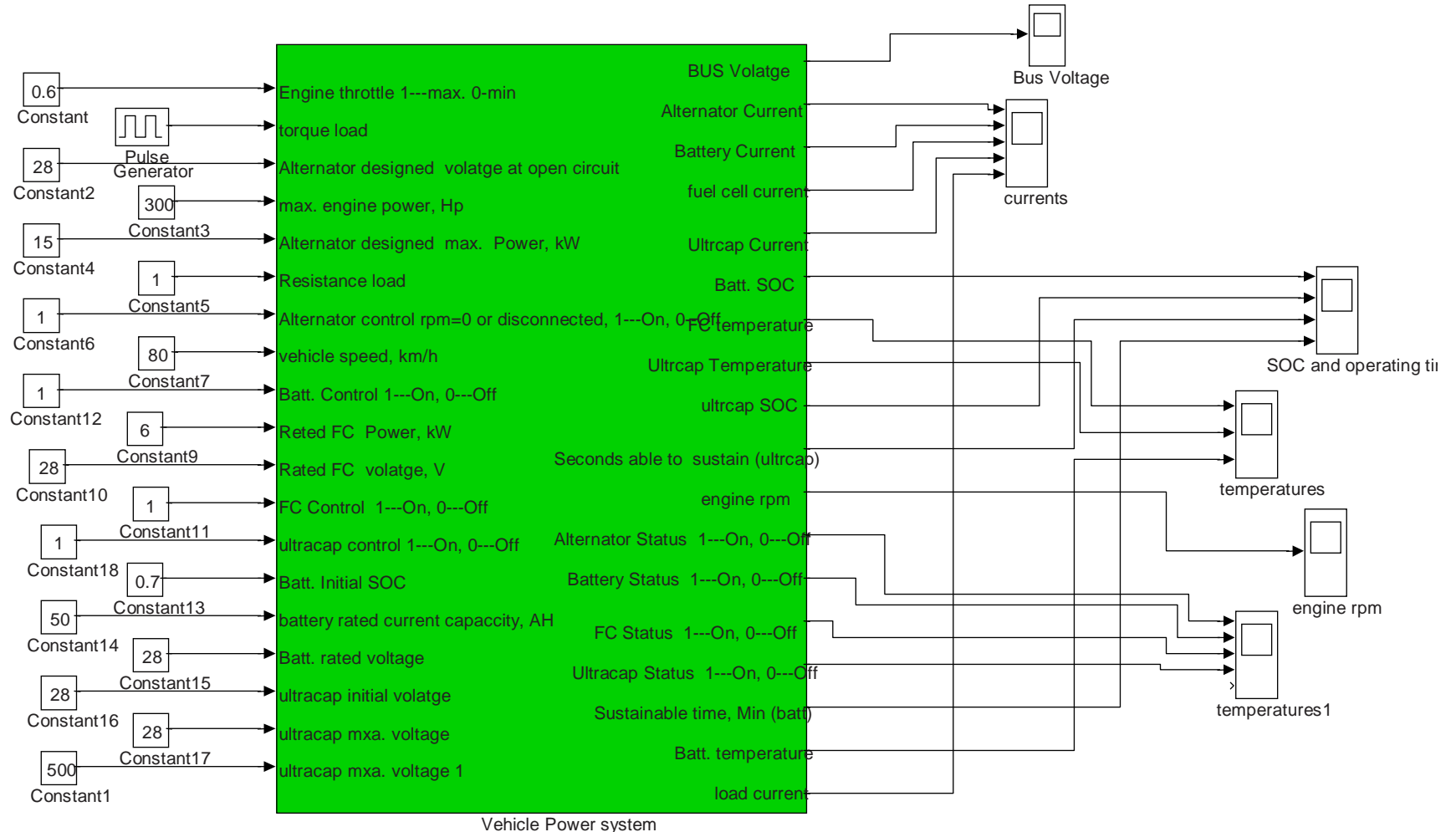

# Modeling and simulation ---System Level

- Power system configuration used in our first generation
  - Given a load power profile and control commands, the simulation model gives the DC Bus voltage and currents of all the power sources

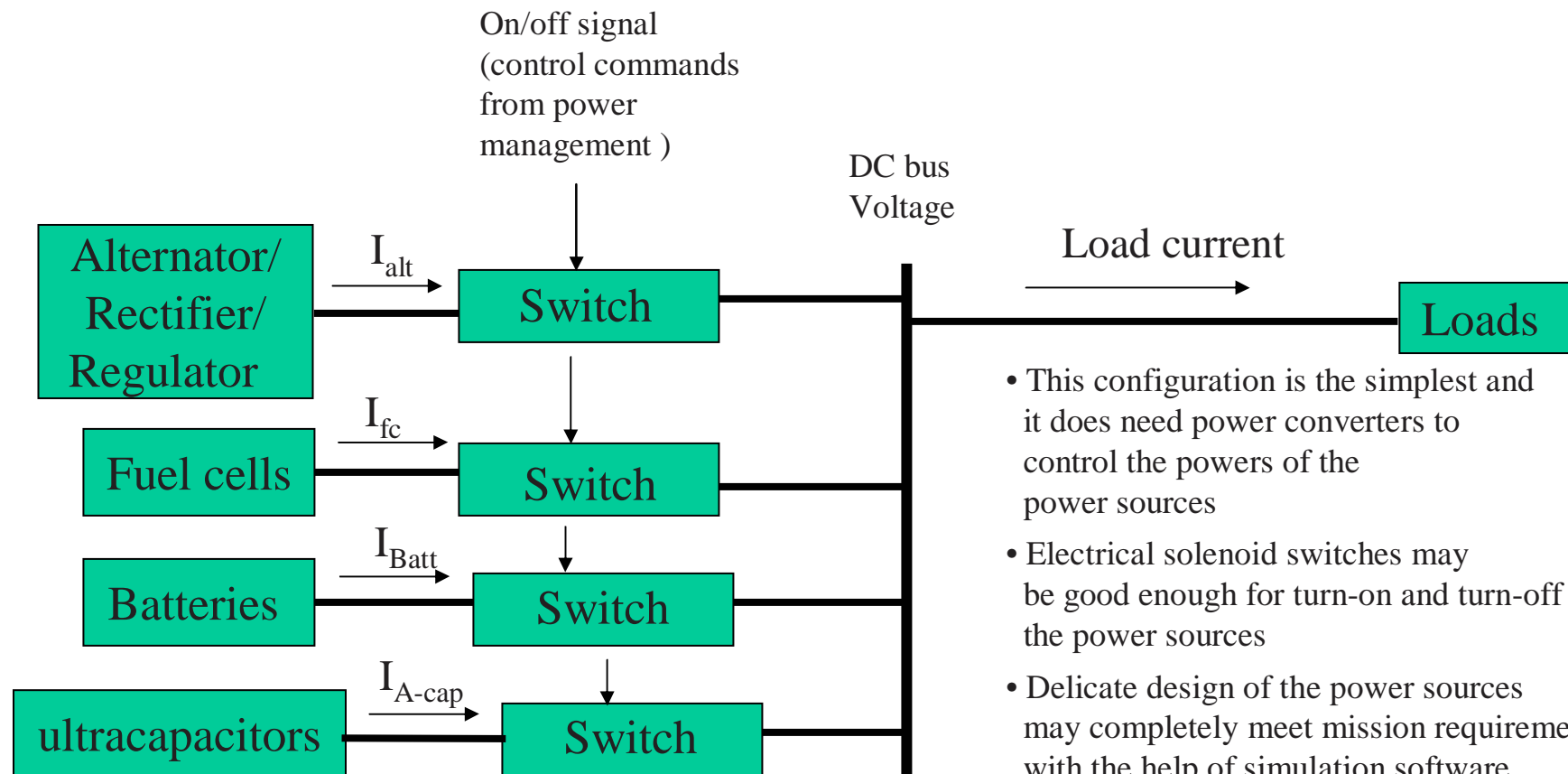

# Modeling and simulation ---System Level

---

Mathematical problem statement in the system simulation model:

$$P_{load} = I_{load} \times V_{bus}$$

$$I_{alt} = f(V_{bus})$$

$$I_{fc} = f(V_{bus})$$

$$I_{batt} = f(V_{bus}, SOC)$$

$$I_{a-cap} = f(V_{bus})$$

*and*

$$I_{alt} + I_{fc} + I_{batt} + I_{a-cap} = I_{load}$$

Solve the equations above to find the  $V_{bus}$ ,  $I_{alt}$ ,  $I_{fc}$ ,  $I_{batt}$  and  $I_{a-cap}$

# Modeling and simulation ---System Level

---

- Calculation of the time that the batteries can sustain operation
  - State-of-charge (SOC) of the batteries is a good index that tells how much energy remains in the batteries
  - A more direct and visible way may be the battery time remaining to sustain the operation
  - The sustaining time can be calculated as

$$T = \frac{Q_s (SOC - SOC_{\min})}{I_{batt}}$$

$Q_s$ ---Rated battery capacity, SOC---present state-of-charge,  $SOC_{\min}$ ---minimum soc allowed

- In discharging, the battery current  $I_{batt}$  can be taken as present current or the average of the past
- In charging, the present battery current  $I_{batt}$  can not be used



# Modeling and simulation ---System Level

---

- Calculation of the time that the ultracapacitors can sustain operation
  - Same method can be applied in calculating the remaining time of ultracapacitors as that of batteries
  - However, this calculation is less meaningful than for batteries, due to  
The fact that very small amount of energy is in ultracapacitors and only few seconds can completely deplete the energy
  - Actually, the major advantage of ultracapacitors is the high power, rather than energy
  - Therefore, a better indicator may be ready/not ready indicator or the number of pulsed Operations remaining..

# Modeling and simulation ---System Level



Simulink model

Load model

Vehicle model

Alternator/  
Rectifier/  
Regulator  
model

Battery  
model

Fuel Cell  
model

DC bus

Ultracap  
model

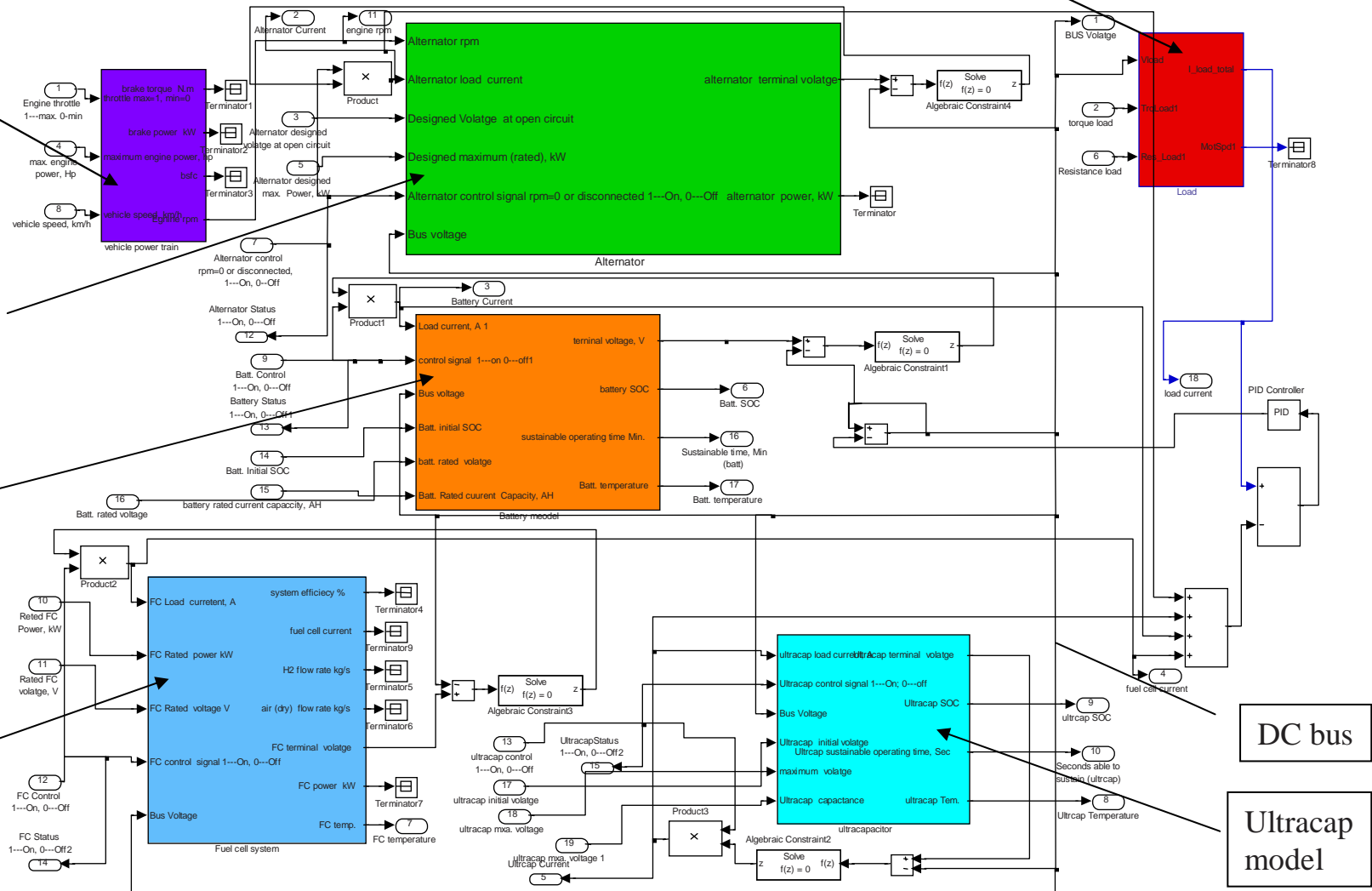

# Modeling and simulation ---System Level



- Simulation results with a constant load power in the mode of all power sources being connected

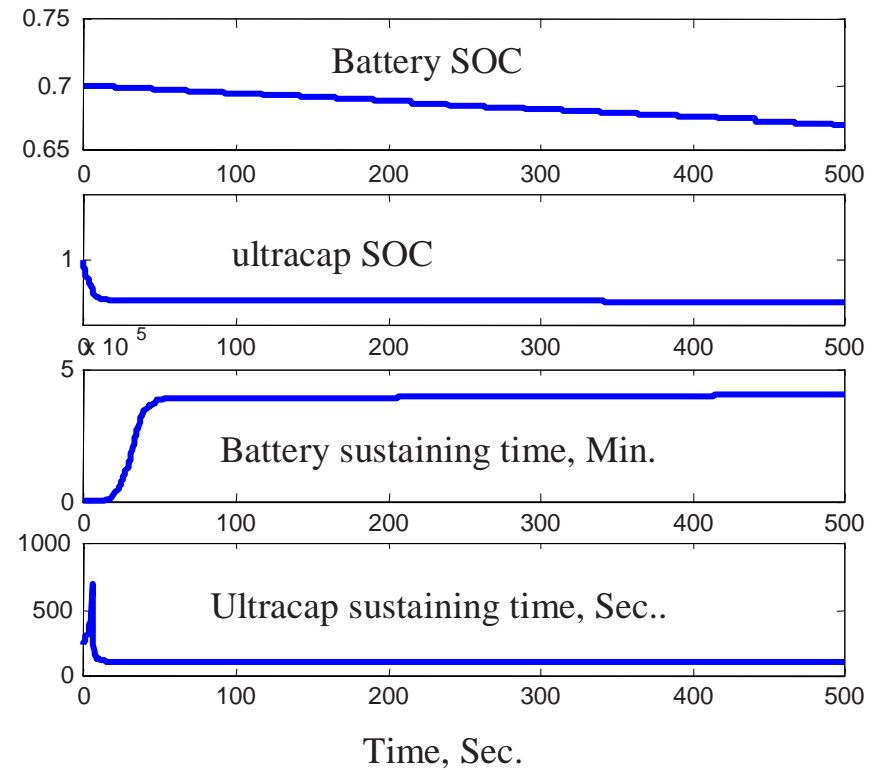
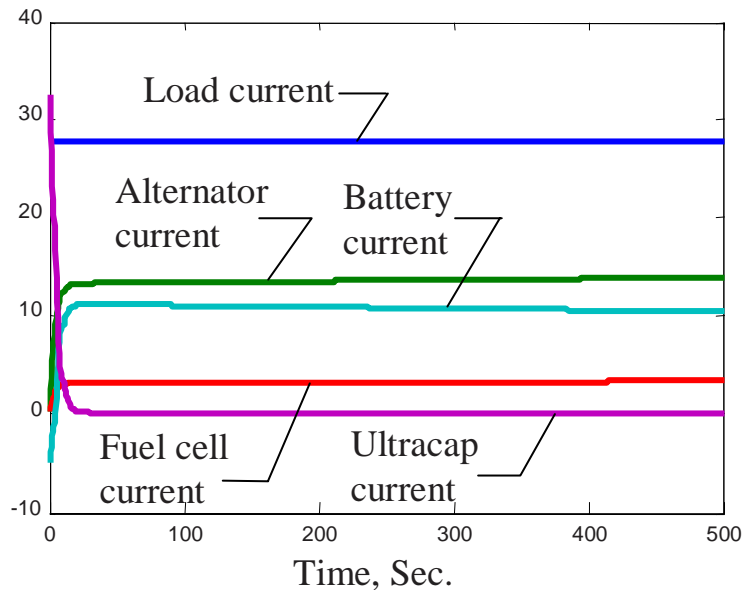
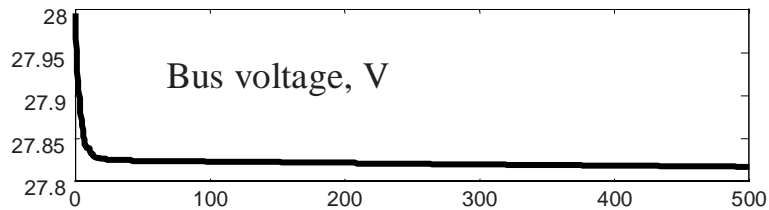

# Modeling and simulation ---System Level



- Simulation results with a constant load power in silent watch mode (alternator off)

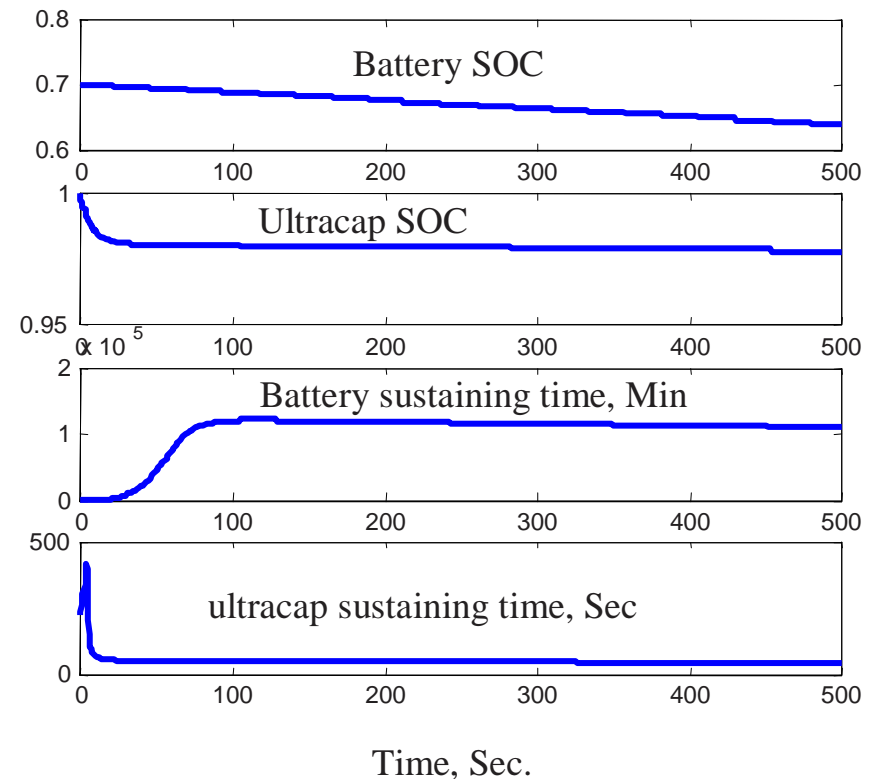
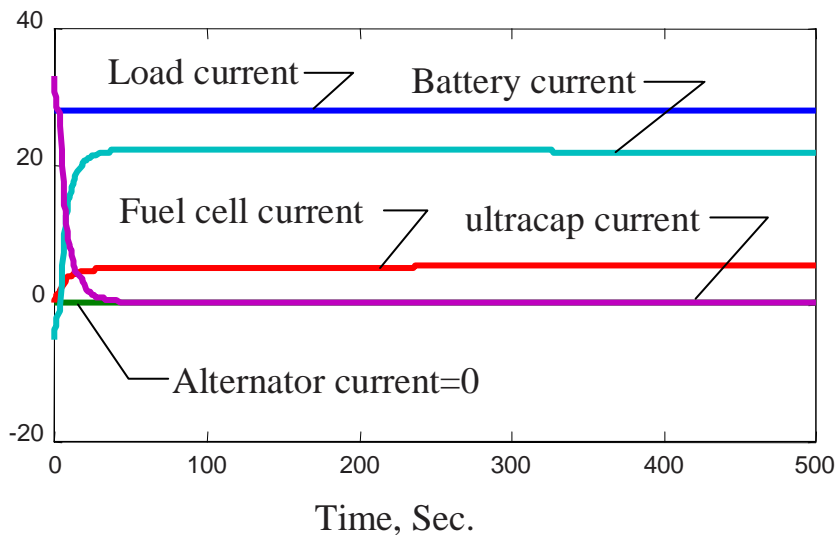
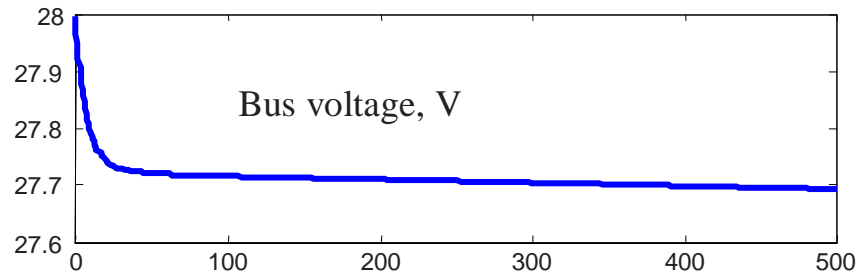

# Modeling and simulation ---System Level

- Simulation results with a pulsed load power in the mode of power sources connected

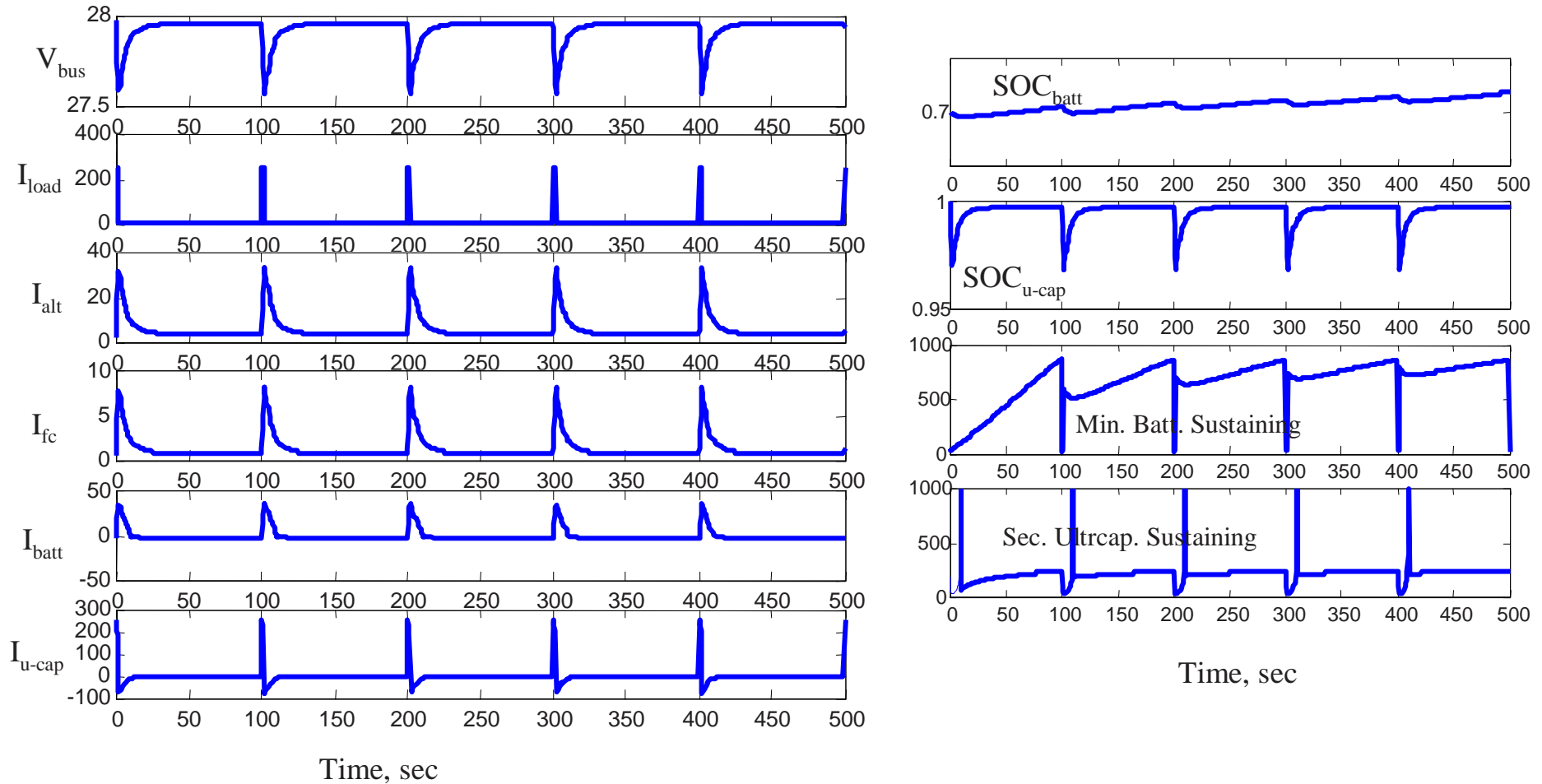

# Modeling and simulation ---System Level



- Simulation results with a pulsed load power in salient watch mode (alternator off)

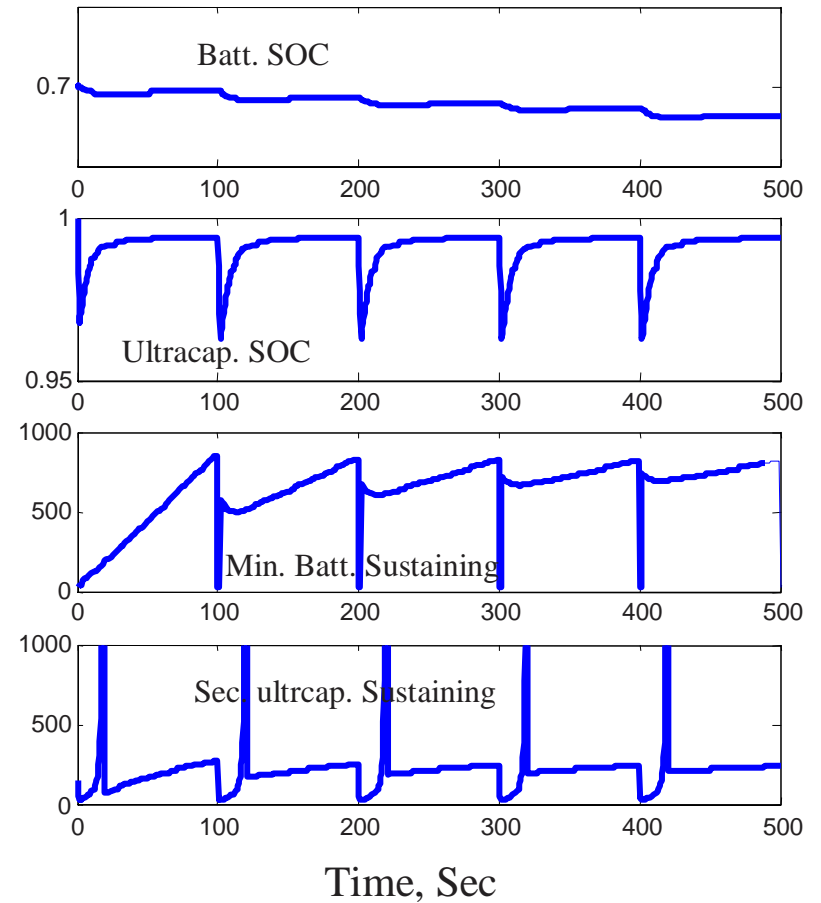
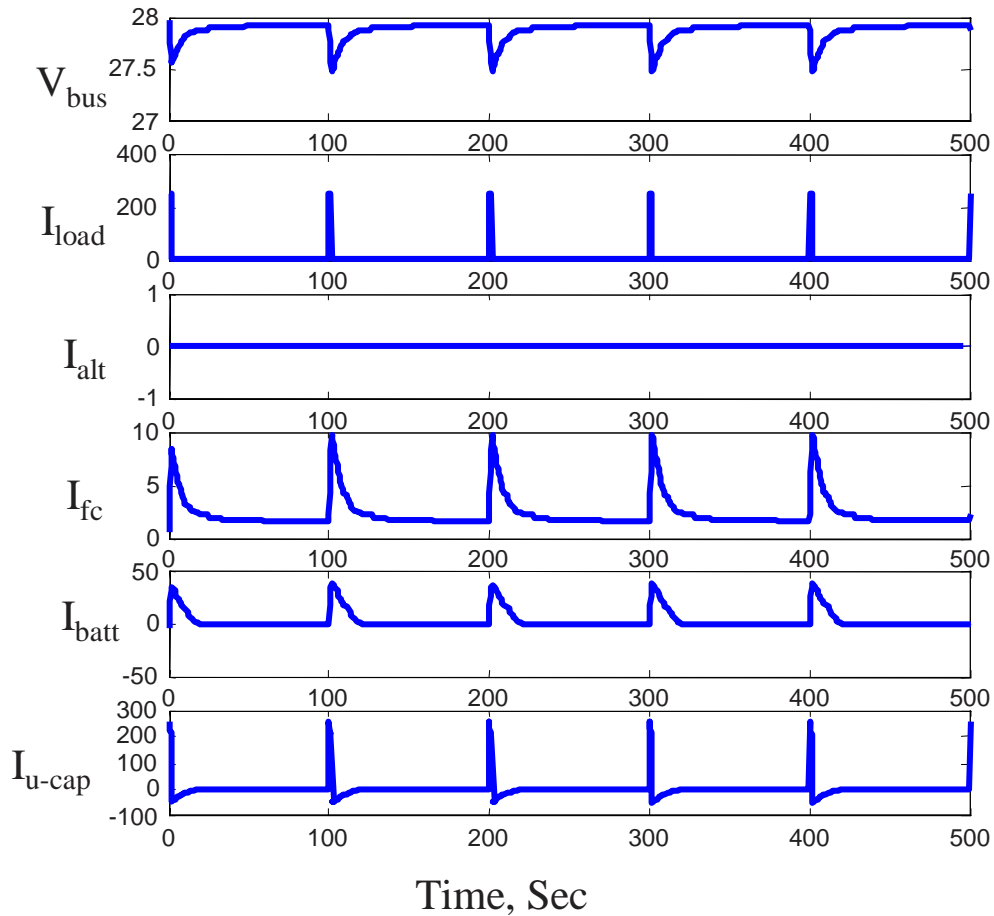

# Modeling and simulation ---System Level



- Power management

- The power management is a microprocessor based control center, which receives control commands, operating status and parameters, makes decisions according to the control rule and commands the components
- When the load is too heavy (over the available power of the power sources), turns off the loads with low priority.
- When the load is too light (much under the rated power of the power sources), turns off the inefficient power source.

- Dr. Masrur suggested a control rule as

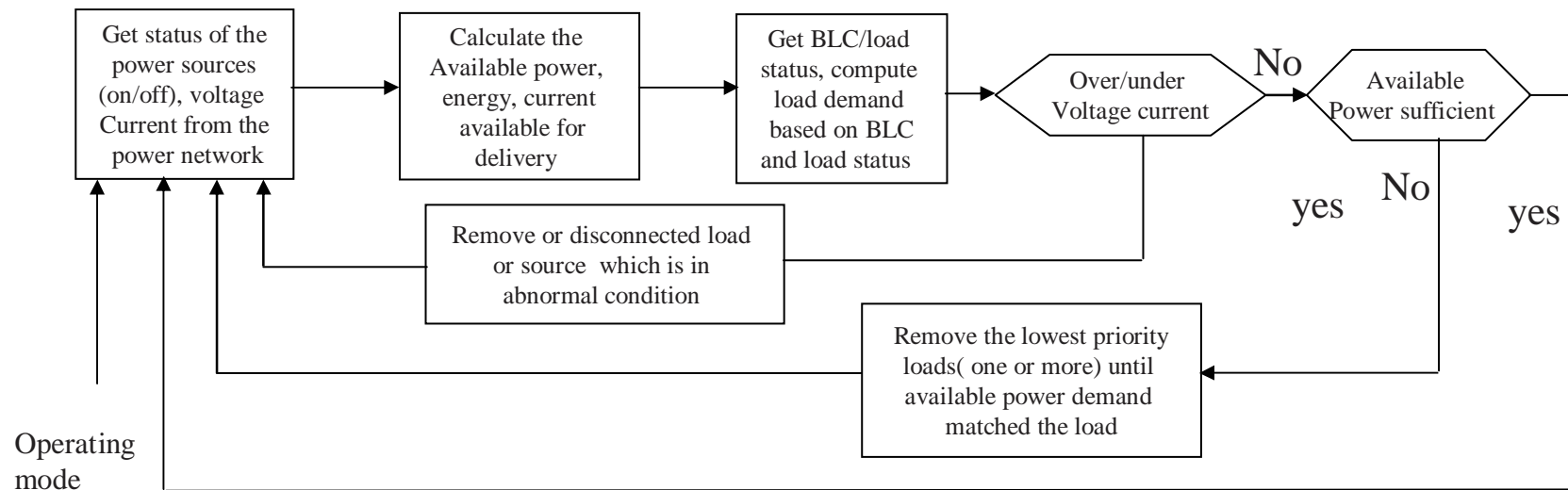

# Modeling and simulation ---System Level

---

- Power management
  - Determination of the maximum power of the power sources
- One simple way may be to set up a minimum bus voltage, at which, the power of each power source is taken as the maximum power.
- Take fuel cell as an example, shown below

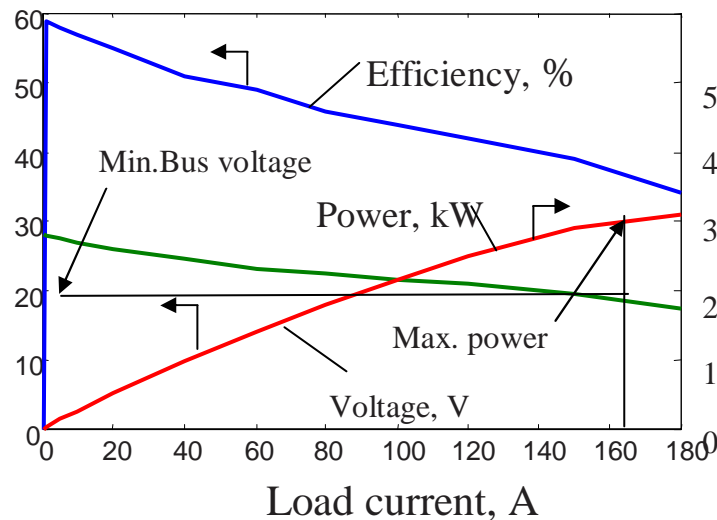

# Modeling and simulation ---System Level

---



- Power management
  - Determine which power source should be turned off at light load
    - A possible way may be to set up priority levels to the power sources according to operating efficiency, thermal management and other factors
    - When the load is very low, turn off the low priority power sources

# Conclusion

---



- Increasing electric loads and multi-mission requirements need smart integrated combat vehicle power systems.
- The power system consists of a power network and an information (signal) network
- The power network supplies the power to the loads in different ways depending on the loads and mission requirements
- The information network and smart power management controls the power flow in the power network.
- A good simulation software can greatly help the understanding of the operation characteristics of the system and can help to design hardware and controls optimally
- Our first generation simulation software shows good performance and establishes The basis for future more detailed, more powerful and accurate simulation software.